

FORMA 1000 ROOM DIVIDER

WITH FLA3+ 790 AUTOMATIC ETHANOL BURNER

BEV Technology®

ROOM DIVIDER FIREPLACE

A unique showstopper for contemporary living rooms or any other open concept interior. The room divider fireplace breaks up the interior, creating two separate spaces with one fireplace.

PROTECTIVE DEFLECTOR

With the attached deflector you can cover the fireplace housing with combustible materials.

BEST BUILD QUALITY

The product passed extensive tests carried out by the leading certification institutes. It is manufactured according to UL standards and is O-TL certified, meeting the most demanding safety and quality requirements.

TRUE ZERO CLEARANCE

The feature that allows you install the fireplace in a housing construction made of combustible materials.



INTEGRATED CONTROL PANEL

The FLA3+ burner has an intuitive control panel with an LCD screen and inlet for automatic refuelling.

REMOTE CONTROL OPTIONS

Control the fire with the included remote, app on your smartphone or home automation system.



GLASS SCREEN

The dedicated toughened glass plate covers the flame making it stable and even.

AUTOMATIC FLA3+ BURNER

The automatic burner with the patented BEV Technology® is the most advanced product in the industry ensuring the cleanest burning process without any smoke, smell or ash. The flame is produced by combusting ethanol vapors and has no direct contact with the liquid fuel.

Forma 1000 Room Divider

Burner model	FLA3+ 790mm (BEV Technology®)
Fuel tank capacity	13.4 L
Maximum burn time	32 hours
Maximum heat output	6.9 kW
Minimum room cubature	69 m ³
Flame height regulation	6 stages
Weight	65.4 kg
Fuel type	bioethanol 86 - 96,6%
Flue	not required
Air change rate	1 space volume per hour
Power supply	230 V
Finish	black powder coating
Materials	steel, galvanized steel, toughened glass
Application	for indoor use only

CONTROL OPTIONS



included



included



optional

'PLANIKA N-CONTROL' APP

Control the fire with your smartphone!



O-TL certified 

Manufactured to UL standards

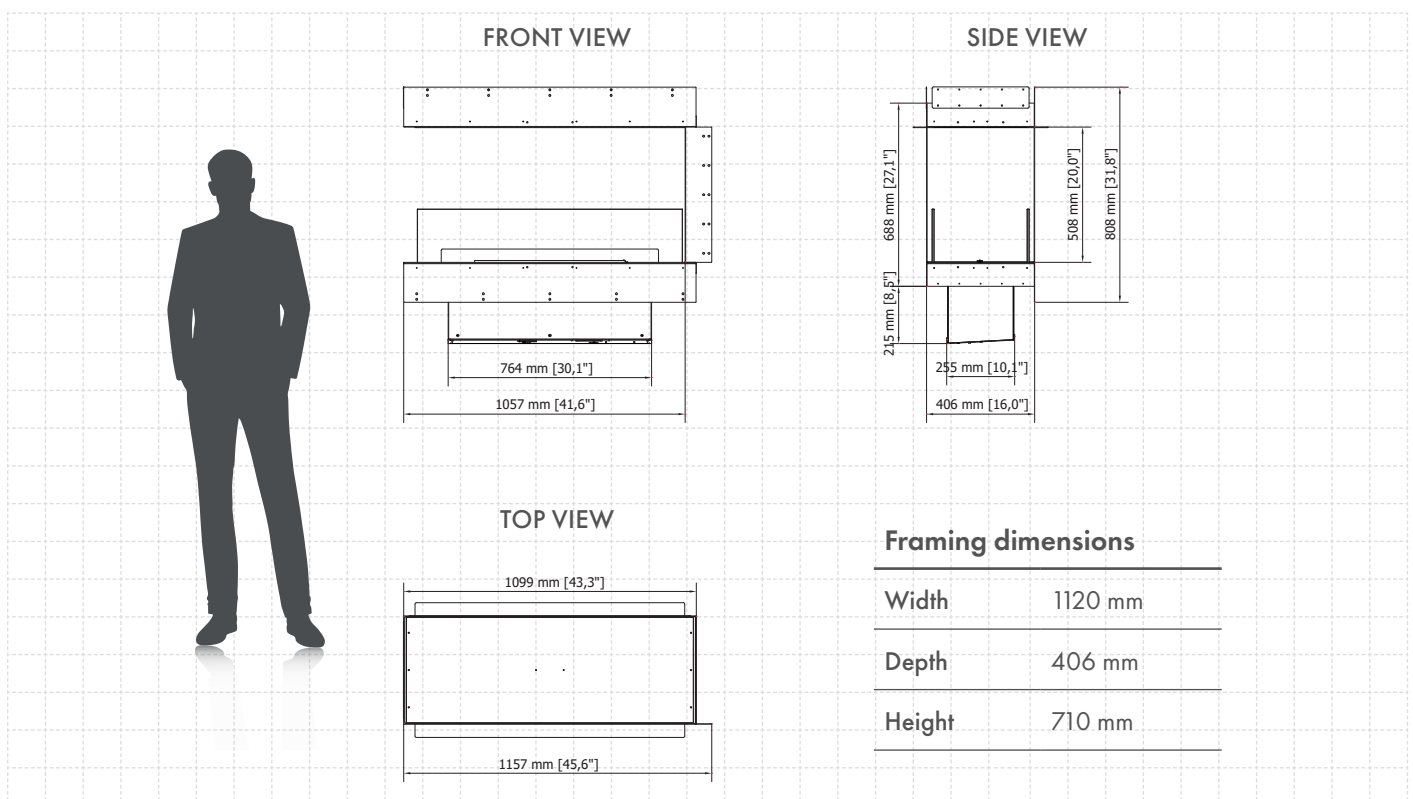

All product specifications and data are subject to change without notice and are believed to be accurate as of the date hereof. Planika Sp. z o.o., its affiliates, agents, and employees, and all persons acting on its or their behalf (collectively, "Planika Sp. z o.o."), disclaim any and all liability for any errors, inaccuracies or incompleteness contained in any document or in any other disclosure relating to any product. To the maximum extent permitted by applicable law, Planika Sp. z o.o. disclaims any and all liability arising out of the application or use of any product. This document does not expand or otherwise modify Planika Sp. z o.o.'s terms and conditions of purchase, including but not limited to the warranty expressed therein. No license, express or implied, by estoppel or otherwise, to any intellectual property rights is granted by this document or by any conduct of Planika Sp. z o.o.. Customers using or selling Planika Sp. z o.o.'s products not expressly indicated for use in such applications do so entirely at their own risk and agree to fully indemnify Planika Sp. z o.o. for any damages arising or resulting from such use or sale. The images are indicative only.

FORMA 1200 ROOM DIVIDER WITH FLA3+ 990 AUTOMATIC ETHANOL BURNER

BEV Technology®

ROOM DIVIDER FIREPLACE

A unique showstopper for contemporary living rooms or any other open concept interior. The room divider fireplace breaks up the interior, creating two separate spaces with one fireplace.

PROTECTIVE DEFLECTOR

With the attached deflector you can cover the fireplace housing with combustible materials.

BEST BUILD QUALITY

The product passed extensive tests carried out by the leading certification institutes. It is manufactured according to UL standards and is O-TL certified, meeting the most demanding safety and quality requirements.

TRUE ZERO CLEARANCE

The feature that allows you install the fireplace in a housing construction made of combustible materials.

INTEGRATED CONTROL PANEL

The FLA3+ burner has an intuitive control panel with an LCD screen and inlet for automatic refuelling.

AUTOMATIC FLA3+ BURNER

The automatic burner with the patented BEV Technology® is the most advanced product in the industry ensuring the cleanest burning process without any smoke, smell or ash. The flame is produced by combusting ethanol vapors and has no direct contact with the liquid fuel.

REMOTE CONTROL OPTIONS

Control the fire with the included remote, app on your smartphone or home automation system.

GLASS SCREEN

The dedicated toughened glass plate covers the flame making it stable and even.



Forma 1200 Room Divider

Burner model	FLA3+ 990 (BEV Technology®)
Fuel tank capacity	17.2 L
Maximum burn time	32 hours
Maximum heat output	8.1 kW
Minimum room cubature	81 m ³
Flame height regulation	6 stages
Weight	77.9 kg
Fuel type	bioethanol 86 - 96,6%
Flue	not required
Air change rate	1 space volume per hour
Power supply	230 V
Finish	black powder coating
Materials	steel, galvanized steel, toughened glass
Application	for indoor use only

CONTROL OPTIONS



included



included



optional

'PLANIKA N-CONTROL' APP

Control the fire with your smartphone!



O-TL certified 

Manufactured to UL standards

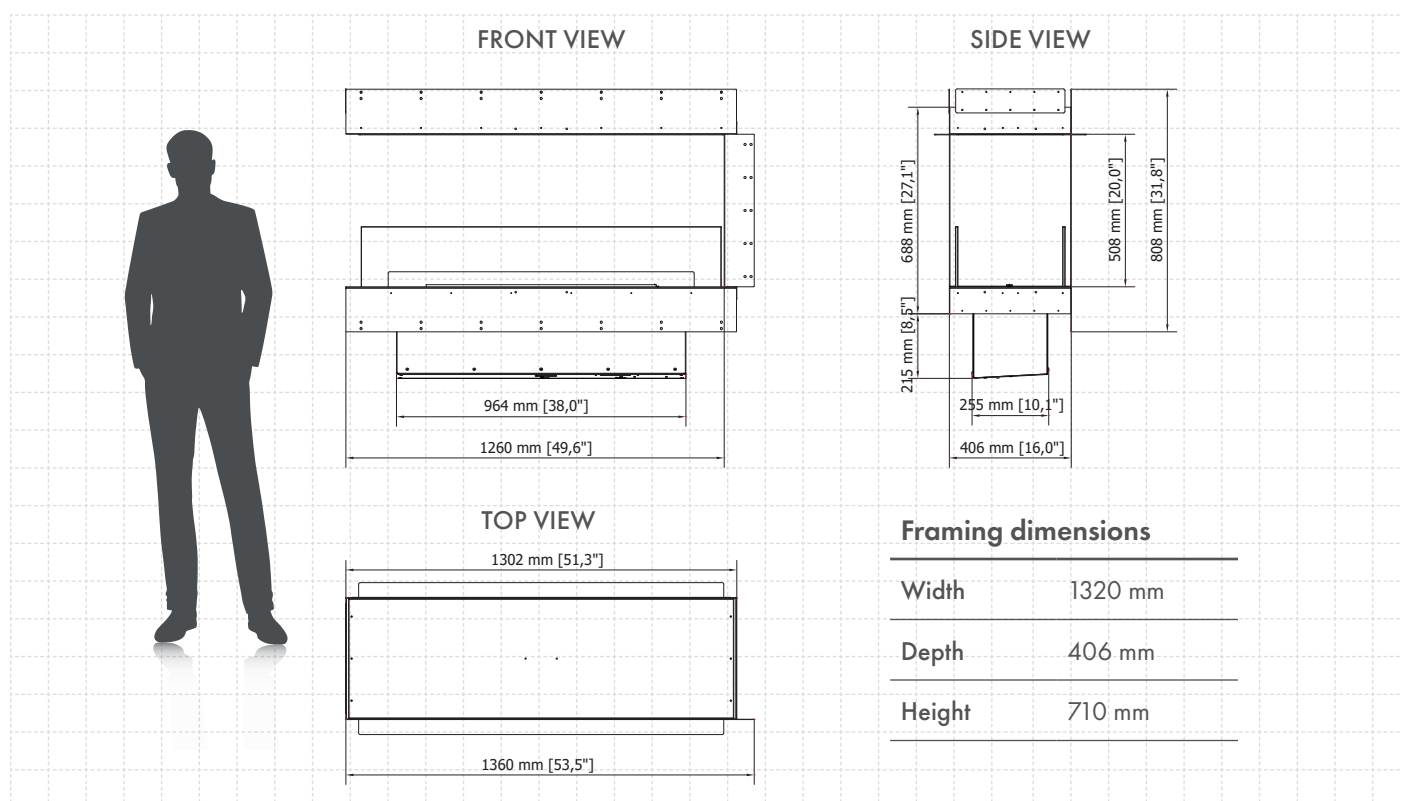

All product specifications and data are subject to change without notice and are believed to be accurate as of the date hereof. Planika Sp. z o.o., its affiliates, agents, and employees, and all persons acting on its or their behalf (collectively, "Planika Sp. z o.o."), disclaim any and all liability for any errors, inaccuracies or incompleteness contained in any document or in any other disclosure relating to any product. To the maximum extent permitted by applicable law, Planika Sp. z o.o. disclaims any and all liability arising out of the application or use of any product. This document does not expand or otherwise modify Planika Sp. z o.o.'s terms and conditions of purchase, including but not limited to the warranty expressed therein. No license, express or implied, by estoppel or otherwise, to any intellectual property rights is granted by this document or by any conduct of Planika Sp. z o.o.. Customers using or selling Planika Sp. z o.o.'s products not expressly indicated for use in such applications do so entirely at their own risk and agree to fully indemnify Planika Sp. z o.o. for any damages arising or resulting from such use or sale. The images are indicative only.

FORMA 1500 ROOM DIVIDER WITH FLA3+ 1190 AUTOMATIC ETHANOL BURNER

BEV Technology®

ROOM DIVIDER FIREPLACE

A unique showstopper for contemporary living rooms or any other open concept interior. The room divider fireplace breaks up the interior, creating two separate spaces with one fireplace.

PROTECTIVE DEFLECTOR

With the attached deflector you can cover the fireplace housing with combustible materials.

BEST BUILD QUALITY

The product passed extensive tests carried out by the leading certification institutes. It is manufactured according to UL standards and is O-TL certified, meeting the most demanding safety and quality requirements.

TRUE ZERO CLEARANCE

The feature that allows you install the fireplace in a housing construction made of combustible materials.



INTEGRATED CONTROL PANEL

The FLA3+ burner has an intuitive control panel with an LCD screen and inlet for automatic

AUTOMATIC FLA3+ BURNER

The automatic burner with the patented BEV Technology® is the most advanced product in the industry ensuring the cleanest burning process without any smoke, smell or ash. The flame is produced by combusting ethanol vapors and has no direct contact with the liquid fuel.

REMOTE CONTROL OPTIONS

Control the fire with the included remote, app on your smartphone or home automation system.

GLASS SCREEN

The dedicated toughened glass plate covers the flame making it stable and even.

Forma 1500 Room Divider

Burner model	FLA3+ 1190 (BEV Technology®)
Fuel tank capacity	21.0 L
Maximum burn time	32 hours
Maximum heat output	11.2 kW
Minimum room cubature	113 m ³
Flame height regulation	6 stages
Weight	94.3 kg
Fuel type	bioethanol 86 - 96,6%
Flue	not required
Air change rate	1 space volume per hour
Power supply	230 V
Finish	black powder coating
Materials	steel, galvanized steel, toughened glass
Application	for indoor use only

CONTROL OPTIONS



included



included



optional

'PLANIKA N-CONTROL' APP

Control the fire with your smartphone!



O-TL certified 

Manufactured to UL standards

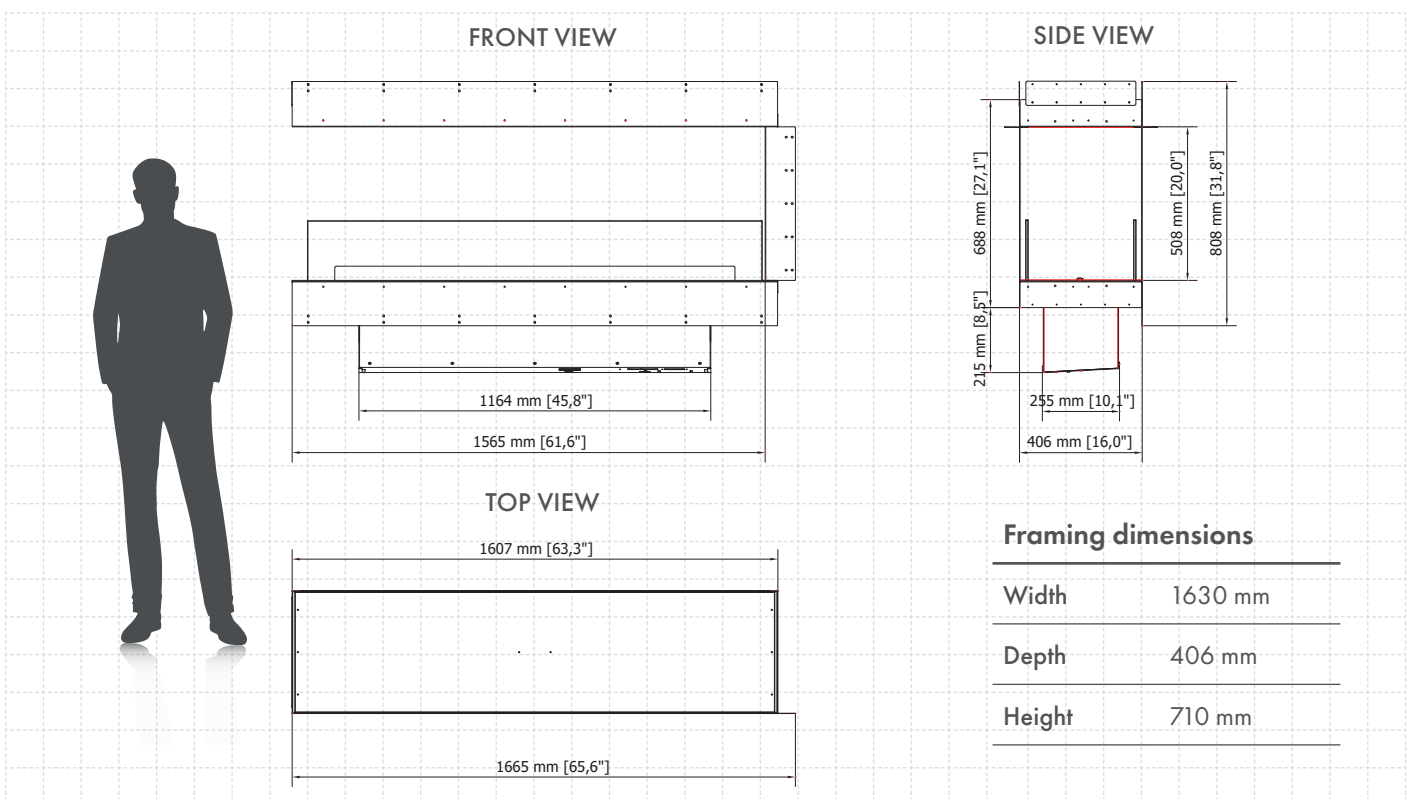

All product specifications and data are subject to change without notice and are believed to be accurate as of the date hereof. Planika Sp. z o.o., its affiliates, agents, and employees, and all persons acting on its or their behalf (collectively, "Planika Sp. z o.o."), disclaim any and all liability for any errors, inaccuracies or incompleteness contained in any document or in any other disclosure relating to any product. To the maximum extent permitted by applicable law, Planika Sp. z o.o. disclaims any and all liability arising out of the application or use of any product. This document does not expand or otherwise modify Planika Sp. z o.o.'s terms and conditions of purchase, including but not limited to the warranty expressed therein. No license, express or implied, by estoppel or otherwise, to any intellectual property rights is granted by this document or by any conduct of Planika Sp. z o.o.. Customers using or selling Planika Sp. z o.o.'s products not expressly indicated for use in such applications do so entirely at their own risk and agree to fully indemnify Planika Sp. z o.o. for any damages arising or resulting from such use or sale. The images are indicative only.

FORMA 1800 ROOM DIVIDER

WITH FLA3+ 1490 AUTOMATIC ETHANOL BURNER

BEV Technology®

ROOM DIVIDER FIREPLACE

A unique showstopper for contemporary living rooms or any other open concept interior. The room divider fireplace breaks up the interior, creating two separate spaces with one fireplace.

PROTECTIVE DEFLECTOR

With the attached deflector you can cover the fireplace housing with combustible materials.

BEST BUILD QUALITY

The product passed extensive tests carried out by the leading certification institutes. It is manufactured according to UL standards and is O-TL certified, meeting the most demanding safety and quality requirements.

TRUE ZERO CLEARANCE

The feature that allows you install the fireplace in a housing construction made of combustible materials.

INTEGRATED CONTROL PANEL

The FLA3+ burner has an intuitive control panel with an LCD screen and inlet for automatic refuelling.

AUTOMATIC FLA3+ BURNER

The automatic burner with the patented BEV Technology® is the most advanced product in the industry ensuring the cleanest burning process without any smoke, smell or ash. The flame is produced by combusting ethanol vapors and has no direct contact with the liquid fuel.

REMOTE CONTROL OPTIONS

Control the fire with the included remote, app on your smartphone or home automation system.

GLASS SCREEN

The dedicated toughened glass plate covers the flame making it stable and even.



Forma 1800 Room Divider

Burner model	FLA3+ 1490 (BEV Technology®)
Fuel tank capacity	26.8 L
Maximum burn time	32 hours
Maximum heat output	15.0 kW
Minimum room cubature	150 m ³
Flame height regulation	6 stages
Weight	110.9 kg
Fuel type	bioethanol 86 - 96,6%
Flue	not required
Air change rate	1 space volume per hour
Power supply	230 V
Finish	black powder coating
Materials	steel, galvanized steel, toughened glass
Application	for indoor use only

CONTROL OPTIONS



included



included



optional

'PLANIKA N-CONTROL' APP

Control the fire with your smartphone!

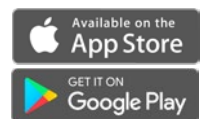

O-TL certified 

Manufactured to UL standards

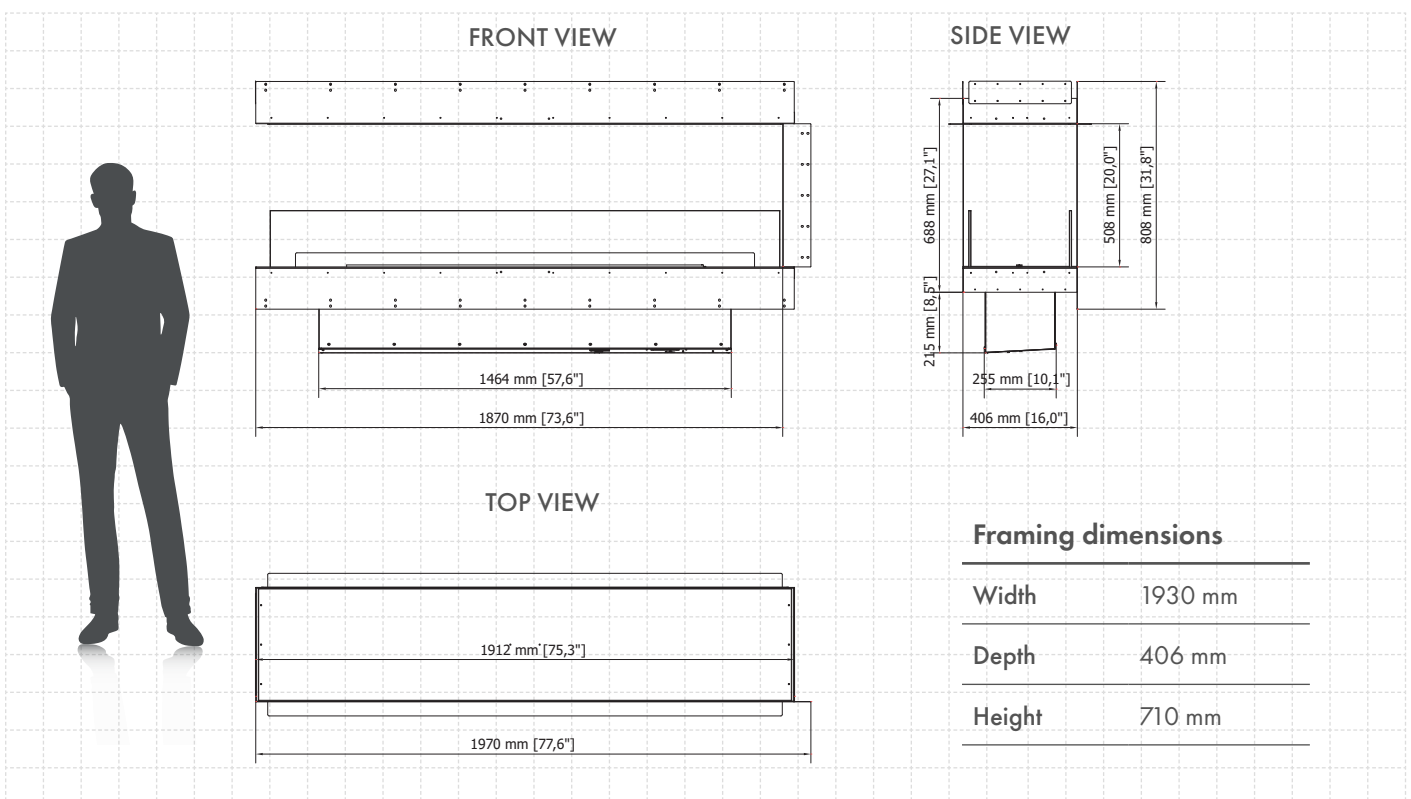

All product specifications and data are subject to change without notice and are believed to be accurate as of the date hereof. Planika Sp. z o.o., its affiliates, agents, and employees, and all persons acting on its or their behalf (collectively, "Planika Sp. z o.o."), disclaim any and all liability for any errors, inaccuracies or incompleteness contained in any document or in any other disclosure relating to any product. To the maximum extent permitted by applicable law, Planika Sp. z o.o. disclaims any and all liability arising out of the application or use of any product. This document does not expand or otherwise modify Planika Sp. z o.o.'s terms and conditions of purchase, including but not limited to the warranty expressed therein. No license, express or implied, by estoppel or otherwise, to any intellectual property rights is granted by this document or by any conduct of Planika Sp. z o.o.. Customers using or selling Planika Sp. z o.o.'s products not expressly indicated for use in such applications do so entirely at their own risk and agree to fully indemnify Planika Sp. z o.o. for any damages arising or resulting from such use or sale. The images are indicative only.

FORMA 2300 ROOM DIVIDER

WITH FLA3+ 1990 AUTOMATIC ETHANOL BURNER

BEV Technology®

ROOM DIVIDER FIREPLACE

A unique showstopper for contemporary living rooms or any other open concept interior. The room divider fireplace breaks up the interior, creating two separate spaces with one fireplace.

PROTECTIVE DEFLECTOR

With the attached deflector you can cover the fireplace housing with combustible materials.

BEST BUILD QUALITY

The product passed extensive tests carried out by the leading certification institutes. It is manufactured according to UL standards and is O-TL certified, meeting the most demanding safety and quality requirements.

TRUE ZERO CLEARANCE

The feature that allows you install the fireplace in a housing construction made of combustible materials.

INTEGRATED CONTROL PANEL

The FLA3+ burner has an intuitive control panel with an LCD screen and inlet for automatic refuelling.

AUTOMATIC FLA3+ BURNER

The automatic burner with the patented BEV Technology® is the most advanced product in the industry ensuring the cleanest burning process without any smoke, smell or ash. The flame is produced by combusting ethanol vapors and has no direct contact with the liquid fuel.

REMOTE CONTROL OPTIONS

Control the fire with the included remote, app on your smartphone or home automation system.

GLASS SCREEN

The dedicated toughened glass plate covers the flame making it stable and even.



Forma 2300 Room Divider

Burner model	FLA3+ 1990 (BEV Technology®)
Fuel tank capacity	36.3 L
Maximum burn time	32 hours
Maximum heat output	21.2 kW
Minimum room cubature	212 m ³
Flame height regulation	6 stages
Weight	154.7 kg
Fuel type	bioethanol 86 - 96,6%
Flue	not required
Air change rate	1 space volume per hour
Power supply	230 V
Finish	black powder coating
Materials	steel, galvanized steel, toughened glass
Application	for indoor use only

CONTROL OPTIONS



included



included



optional

'PLANIKA N-CONTROL' APP

Control the fire with your smartphone!

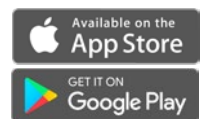

O-TL certified 

Manufactured to UL standards

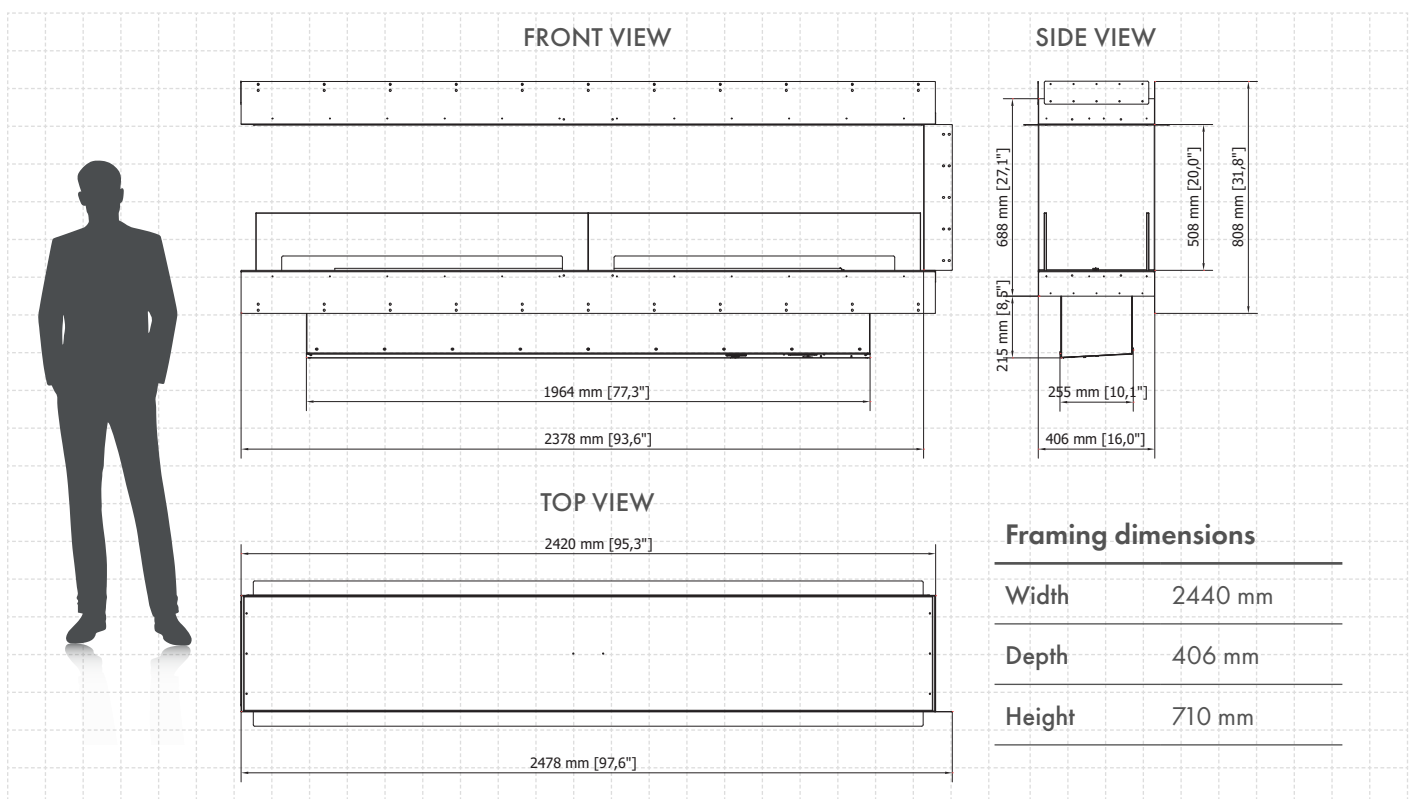

All product specifications and data are subject to change without notice and are believed to be accurate as of the date hereof. Planika Sp. z o.o., its affiliates, agents, and employees, and all persons acting on its or their behalf (collectively, "Planika Sp. z o.o."), disclaim any and all liability for any errors, inaccuracies or incompleteness contained in any document or in any other disclosure relating to any product. To the maximum extent permitted by applicable law, Planika Sp. z o.o. disclaims any and all liability arising out of the application or use of any product. This document does not expand or otherwise modify Planika Sp. z o.o.'s terms and conditions of purchase, including but not limited to the warranty expressed therein. No license, express or implied, by estoppel or otherwise, to any intellectual property rights is granted by this document or by any conduct of Planika Sp. z o.o.. Customers using or selling Planika Sp. z o.o.'s products not expressly indicated for use in such applications do so entirely at their own risk and agree to fully indemnify Planika Sp. z o.o. for any damages arising or resulting from such use or sale. The images are indicative only.

FORMA 2700 ROOM DIVIDER WITH FLA3+ 2490 AUTOMATIC ETHANOL BURNER

BEV Technology®

ROOM DIVIDER FIREPLACE

A unique showstopper for contemporary living rooms or any other open concept interior. The room divider fireplace breaks up the interior, creating two separate

PROTECTIVE DEFLECTOR

With the attached deflector you can cover the fireplace housing with combustible materials.

BEST BUILD QUALITY

The product passed extensive tests carried out by the leading certification institutes. It is manufactured according to UL standards and is O-TL certified, meeting the most demanding safety and quality requirements.

TRUE ZERO CLEARANCE

The feature that allows you install the fireplace in a housing construction made of combustible materials.

INTEGRATED CONTROL PANEL

The FLA3+ burner has an intuitive control panel with an LCD screen and inlet for automatic refuelling.

AUTOMATIC FLA3+ BURNER

The automatic burner with the patented BEV Technology® is the most advanced product in the industry ensuring the cleanest burning process without any smoke, smell or ash. The flame is produced by combusting ethanol vapors and has no direct contact with the liquid fuel.

REMOTE CONTROL OPTIONS

Control the fire with the included remote, app on your smartphone or home automation system.

GLASS SCREEN

The dedicated toughened glass plate covers the flame making it stable and even.



Forma 2700 Room Divider

Burner model	FLA3+ 2490 (BEV Technology®)
Fuel tank capacity	45.9 L
Maximum burn time	32 hours
Maximum heat output	27.5 kW
Minimum room cubature	275 m ³
Flame height regulation	6 stages
Weight	227.3 kg
Fuel type	bioethanol 86 - 96,6%
Flue	not required
Air change rate	1 space volume per hour
Power supply	230 V
Finish	black powder coating
Materials	steel, galvanized steel, toughened glass
Application	for indoor use only

CONTROL OPTIONS



included



included



optional

'PLANIKA N-CONTROL' APP

Control the fire with your smartphone!



O-TL certified 

Manufactured to UL standards

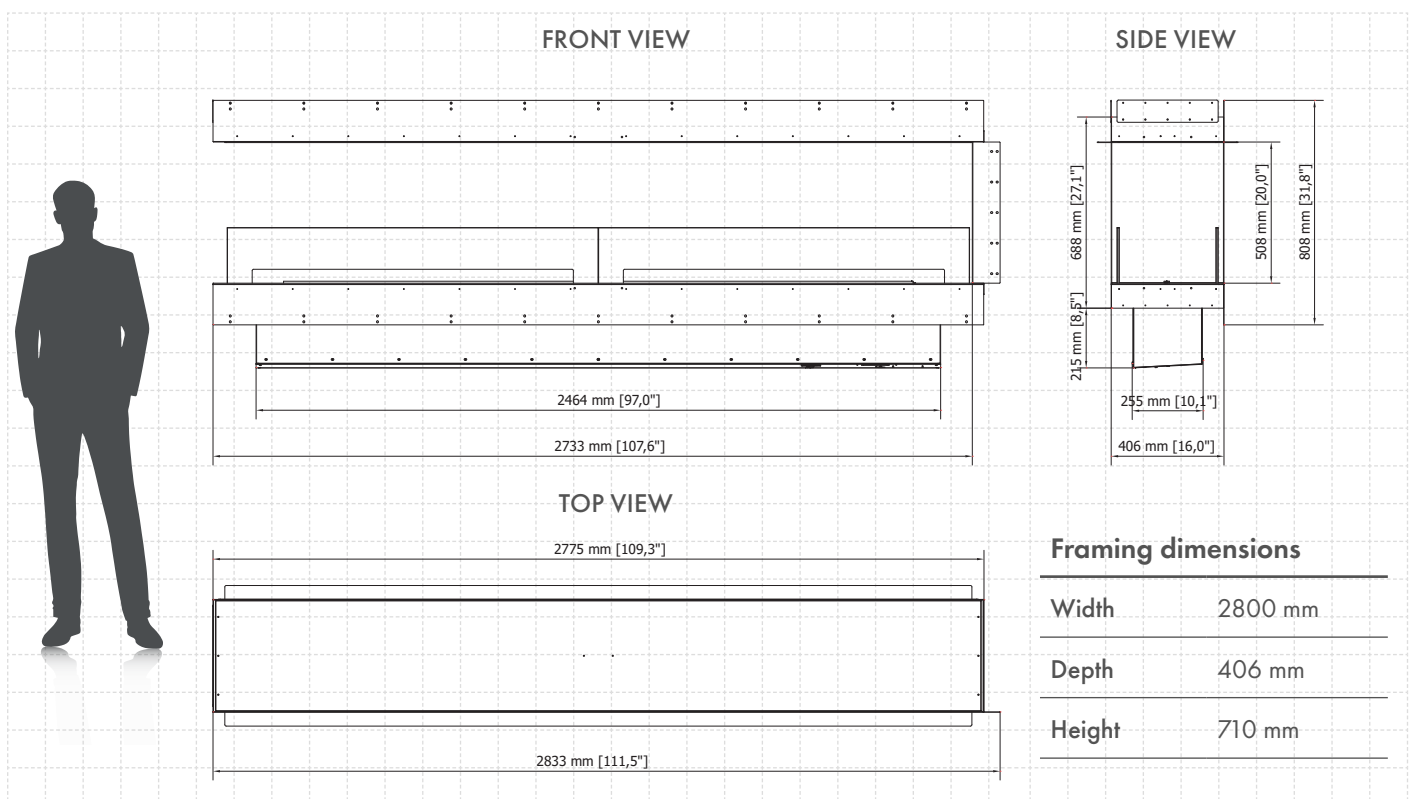

All product specifications and data are subject to change without notice and are believed to be accurate as of the date hereof. Planika Sp. z o.o., its affiliates, agents, and employees, and all persons acting on its or their behalf (collectively, "Planika Sp. z o.o."), disclaim any and all liability for any errors, inaccuracies or incompleteness contained in any document or in any other disclosure relating to any product. To the maximum extent permitted by applicable law, Planika Sp. z o.o. disclaims any and all liability arising out of the application or use of any product. This document does not expand or otherwise modify Planika Sp. z o.o.'s terms and conditions of purchase, including but not limited to the warranty expressed therein. No license, express or implied, by estoppel or otherwise, to any intellectual property rights is granted by this document or by any conduct of Planika Sp. z o.o.. Customers using or selling Planika Sp. z o.o.'s products not expressly indicated for use in such applications do so entirely at their own risk and agree to fully indemnify Planika Sp. z o.o. for any damages arising or resulting from such use or sale. The images are indicative only.

FORMA 1000 ROOM DIVIDER WITH FLA3 790 AUTOMATIC ETHANOL BURNER

BEV Technology®

PENINSULA FIREPLACE

A unique showstopper for contemporary living rooms or any other open concept interior. The peninsula fireplace breaks up the interior, creating two separate spaces with one fireplace.

PROTECTIVE DEFLECTOR

With the attached deflector you can cover the fireplace housing with combustible materials.

BEST BUILD QUALITY

The product passed extensive tests carried out by the leading certification institutes. It is manufactured according to UL standards and is O-TL certified, meeting the most demanding safety and quality requirements.

TRUE ZERO CLEARANCE

The feature that allows you install the fireplace in a housing construction made of combustible materials.

INTEGRATED CONTROL PANEL

The FLA3 burner has an intuitive control panel with an LCD screen and inlet for automatic refuelling.

AUTOMATIC FLA3 BURNER

The automatic burner with the patented BEV Technology® is the most advanced product in the industry ensuring the cleanest burning process without any smoke, smell or ash. The flame is produced by combusting ethanol vapors and has no direct contact with the liquid fuel.

REMOTE CONTROL OPTIONS

Control the fire with the included remote, app on your smartphone or home automation system.

GLASS SCREEN

The dedicated toughened glass plate covers the flame making it stable and even.



Forma 1000 Room Divider

Burner model	FLA3 790mm (BEV Technology®)
Fuel tank capacity	4.3 L
Maximum burn time	9 hours
Maximum heat output	4.4 kW
Minimum room cubature	44 m ³
Flame height regulation	6 stages
Weight	60.5 kg
Fuel type	bioethanol 86 - 96,6%
Flue	not required
Air change rate	1 space volume per hour
Power supply	230 V
Finish	black powder coating
Materials	steel, galvanized steel, toughened glass
Application	for indoor use only

CONTROL OPTIONS



included



included



optional

'PLANIKA N-CONTROL' APP

Control the fire with your smartphone!

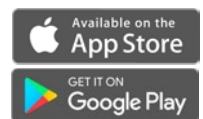

O-TL certified 

Manufactured to UL standards

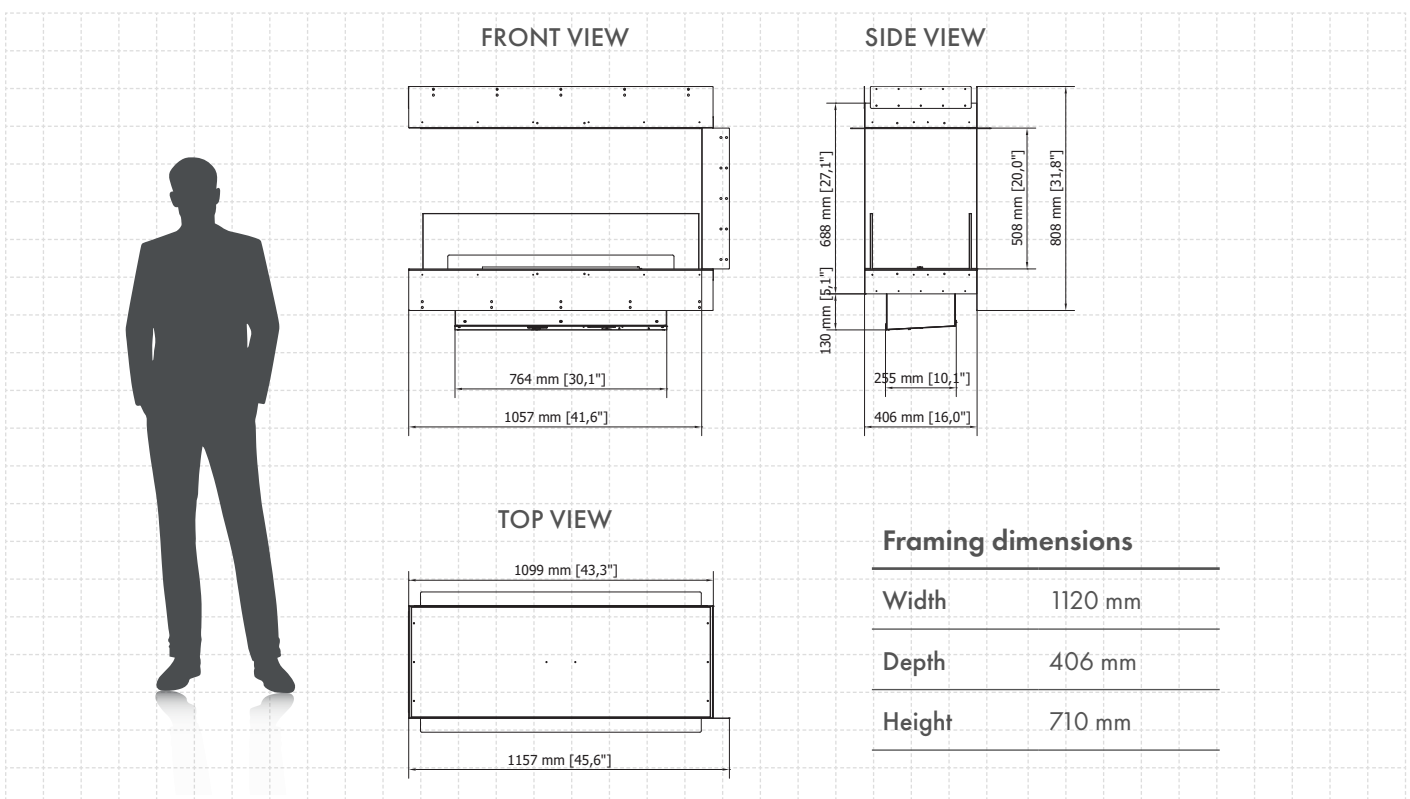

All product specifications and data are subject to change without notice and are believed to be accurate as of the date hereof. Planika Sp. z o.o., its affiliates, agents, and employees, and all persons acting on its or their behalf (collectively, "Planika Sp. z o.o."), disclaim any and all liability for any errors, inaccuracies or incompleteness contained in any document or in any other disclosure relating to any product. To the maximum extent permitted by applicable law, Planika Sp. z o.o. disclaims any and all liability arising out of the application or use of any product. This document does not expand or otherwise modify Planika Sp. z o.o.'s terms and conditions of purchase, including but not limited to the warranty expressed therein. No license, express or implied, by estoppel or otherwise, to any intellectual property rights is granted by this document or by any conduct of Planika Sp. z o.o.. Customers using or selling Planika Sp. z o.o.'s products not expressly indicated for use in such applications do so entirely at their own risk and agree to fully indemnify Planika Sp. z o.o. for any damages arising or resulting from such use or sale. The images are indicative only.

FORMA 1200 ROOM DIVIDER WITH FLA3 990 AUTOMATIC ETHANOL BURNER

BEV Technology®

PENINSULA FIREPLACE

A unique showstopper for contemporary living rooms or any other open concept interior. The peninsula fireplace breaks up the interior, creating two separate spaces with one fireplace.

PROTECTIVE DEFLECTOR

With the attached deflector you can cover the fireplace housing with combustible materials.

BEST BUILD QUALITY

The product passed extensive tests carried out by the leading certification institutes. It is manufactured according to UL standards and is O-TL certified, meeting the most demanding safety and quality requirements.

TRUE ZERO CLEARANCE

The feature that allows you install the fireplace in a housing construction made of combustible materials.

INTEGRATED CONTROL PANEL

The FLA3 burner has an intuitive control panel with an LCD screen and inlet for automatic refuelling.

AUTOMATIC FLA3 BURNER

The automatic burner with the patented BEV Technology® is the most advanced product in the industry ensuring the cleanest burning process without any smoke, smell or ash. The flame is produced by combusting ethanol vapors and has no direct contact with the liquid fuel.

REMOTE CONTROL OPTIONS

Control the fire with the included remote, app on your smartphone or home automation system.

GLASS SCREEN

The dedicated toughened glass plate covers the flame making it stable and even.



Forma 1200 Room Divider

Burner model	FLA3 990 (BEV Technology®)
Fuel tank capacity	5.5 L
Maximum burn time	10 hours
Maximum heat output	7.0 kW
Minimum room cubature	70 m ³
Flame height regulation	6 stages
Weight	69.4 kg
Fuel type	bioethanol 86 - 96,6%
Flue	not required
Air change rate	1 space volume per hour
Power supply	230 V
Finish	black powder coating
Materials	steel, galvanized steel, toughened glass
Application	for indoor use only

CONTROL OPTIONS



included



included



optional

'PLANIKA N-CONTROL' APP

Control the fire with your smartphone!

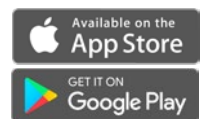

O-TL certified 

Manufactured to UL standards

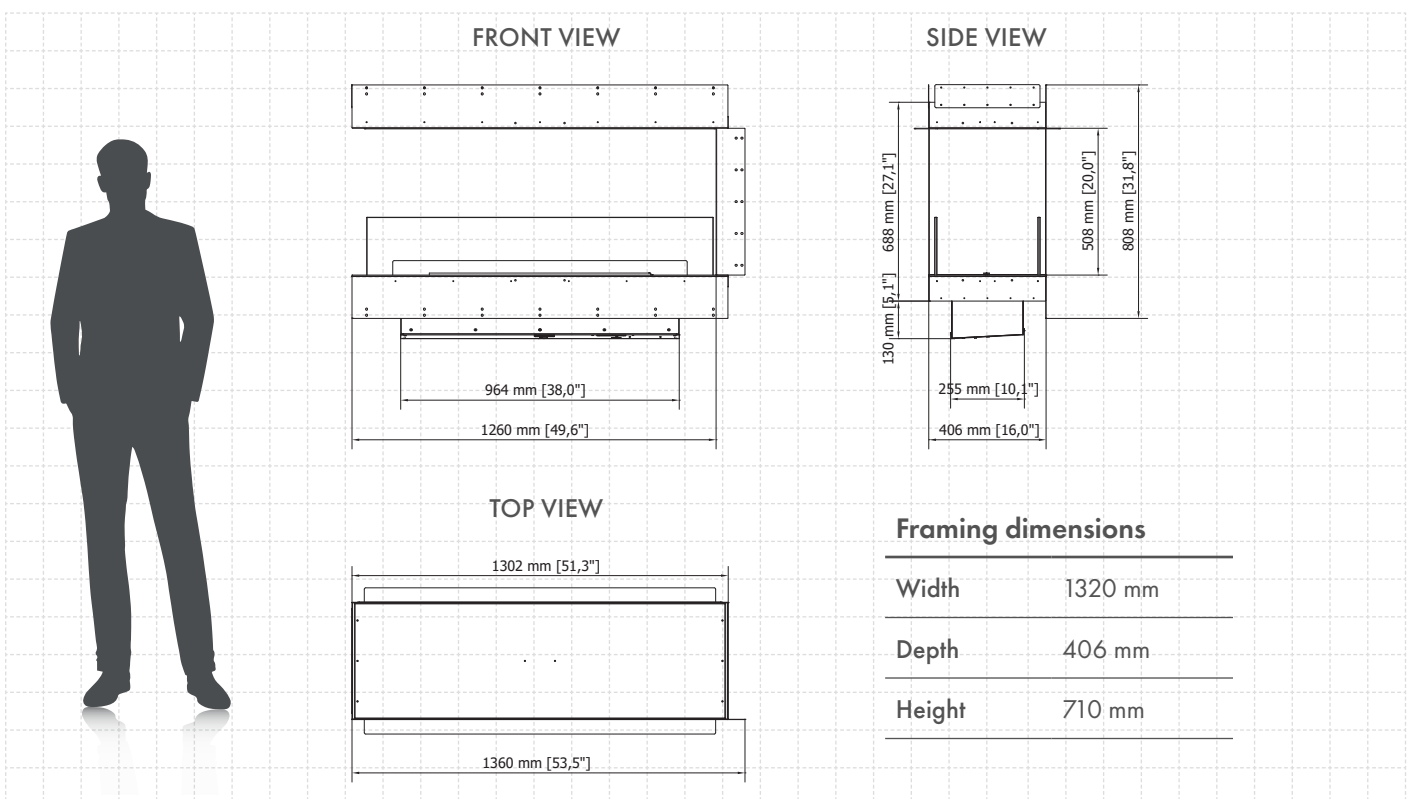

All product specifications and data are subject to change without notice and are believed to be accurate as of the date hereof. Planika Sp. z o.o., its affiliates, agents, and employees, and all persons acting on its or their behalf (collectively, "Planika Sp. z o.o."), disclaim any and all liability for any errors, inaccuracies or incompleteness contained in any document or in any other disclosure relating to any product. To the maximum extent permitted by applicable law, Planika Sp. z o.o. disclaims any and all liability arising out of the application or use of any product. This document does not expand or otherwise modify Planika Sp. z o.o.'s terms and conditions of purchase, including but not limited to the warranty expressed therein. No license, express or implied, by estoppel or otherwise, to any intellectual property rights is granted by this document or by any conduct of Planika Sp. z o.o.. Customers using or selling Planika Sp. z o.o.'s products not expressly indicated for use in such applications do so entirely at their own risk and agree to fully indemnify Planika Sp. z o.o. for any damages arising or resulting from such use or sale. The images are indicative only.

FORMA 1500 ROOM DIVIDER WITH FLA3 1190 AUTOMATIC ETHANOL BURNER

BEV Technology®

PENINSULA FIREPLACE

A unique showstopper for contemporary living rooms or any other open concept interior. The peninsula fireplace breaks up the interior, creating two separate spaces with one fireplace.

PROTECTIVE DEFLECTOR

With the attached deflector you can cover the fireplace housing with combustible materials.

BEST BUILD QUALITY

The product passed extensive tests carried out by the leading certification institutes. It is manufactured according to UL standards and is O-TL certified, meeting the most demanding safety and quality requirements.

TRUE ZERO CLEARANCE

The feature that allows you install the fireplace in a housing construction made of combustible materials.



INTEGRATED CONTROL PANEL

The FLA3 burner has an intuitive control panel with an LCD screen and inlet for automatic refu-

AUTOMATIC FLA3 BURNER

The automatic burner with the patented BEV Technology® is the most advanced product in the industry ensuring the cleanest burning process without any smoke, smell or ash. The flame is produced by combusting ethanol vapors and has no direct contact with the liquid fuel.

REMOTE CONTROL OPTIONS

Control the fire with the included remote, app on your smartphone or home automation system.

GLASS SCREEN

The dedicated toughened glass plate covers the flame making it stable and even.

Forma 1500 Room Divider

Burner model	FLA3 1190 (BEV Technology®)
Fuel tank capacity	6.8 L
Maximum burn time	11 hours
Maximum heat output	9.4 kW
Minimum room cubature	94 m ³
Flame height regulation	6 stages
Weight	84.1 kg
Fuel type	bioethanol 86 - 96,6%
Flue	not required
Air change rate	1 space volume per hour
Power supply	230 V
Finish	black powder coating
Materials	steel, galvanized steel, toughened glass
Application	for indoor use only

CONTROL OPTIONS



included



included



optional

'PLANIKA N-CONTROL' APP

Control the fire with your smartphone!



O-TL certified 

Manufactured to UL standards

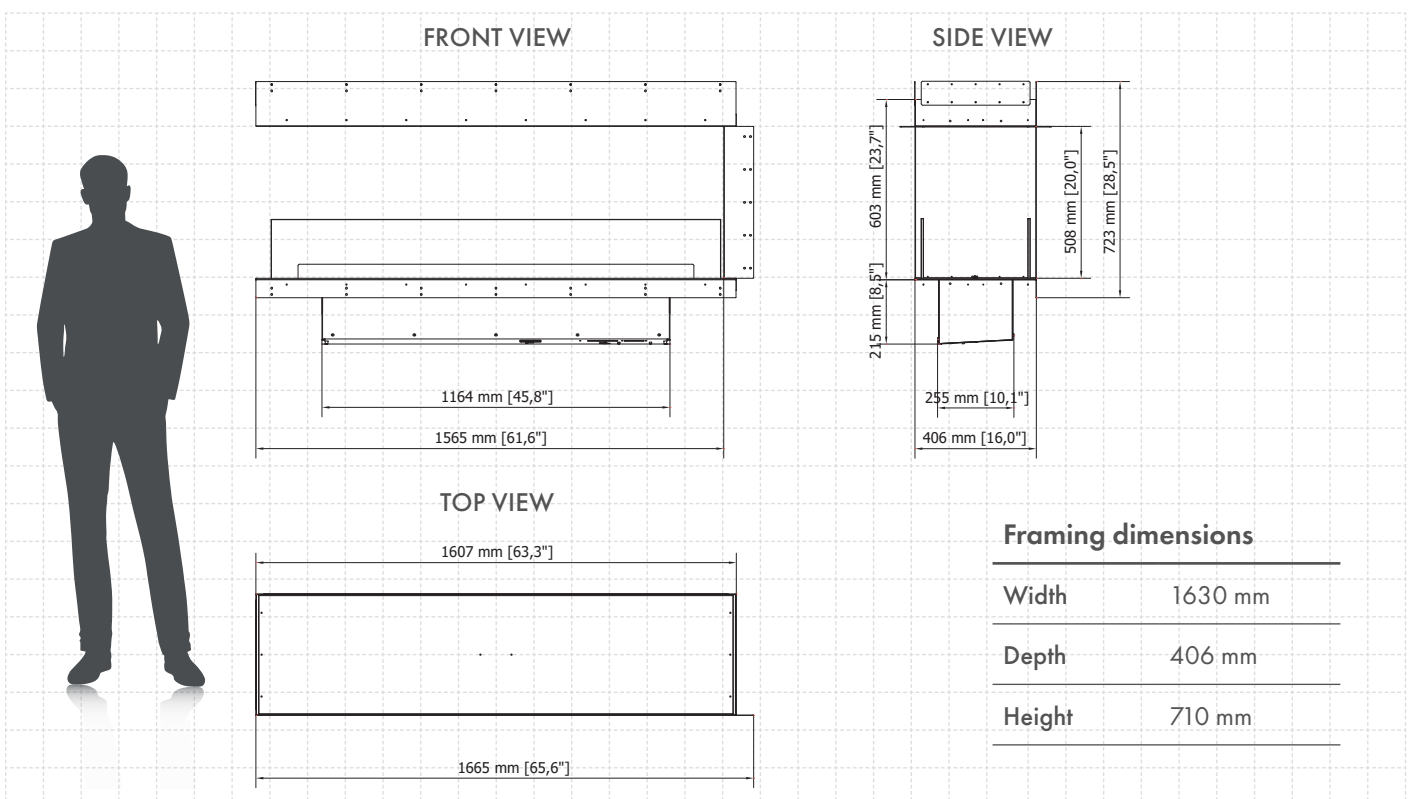

All product specifications and data are subject to change without notice and are believed to be accurate as of the date hereof. Planika Sp. z o.o., its affiliates, agents, and employees, and all persons acting on its or their behalf (collectively, "Planika Sp. z o.o."), disclaim any and all liability for any errors, inaccuracies or incompleteness contained in any document or in any other disclosure relating to any product. To the maximum extent permitted by applicable law, Planika Sp. z o.o. disclaims any and all liability arising out of the application or use of any product. This document does not expand or otherwise modify Planika Sp. z o.o.'s terms and conditions of purchase, including but not limited to the warranty expressed therein. No license, express or implied, by estoppel or otherwise, to any intellectual property rights is granted by this document or by any conduct of Planika Sp. z o.o.. Customers using or selling Planika Sp. z o.o.'s products not expressly indicated for use in such applications do so entirely at their own risk and agree to fully indemnify Planika Sp. z o.o. for any damages arising or resulting from such use or sale. The images are indicative only.

FORMA 1800 ROOM DIVIDER

WITH FLA3 1490 AUTOMATIC ETHANOL BURNER

BEV Technology®

PENINSULA FIREPLACE

A unique showstopper for contemporary living rooms or any other open concept interior. The peninsula fireplace breaks up the interior, creating two separate spaces with one fireplace.

PROTECTIVE DEFLECTOR

With the attached deflector you can cover the fireplace housing with combustible materials.

BEST BUILD QUALITY

The product passed extensive tests carried out by the leading certification institutes. It is manufactured according to UL standards and is O-TL certified, meeting the most demanding safety and quality requirements.

TRUE ZERO CLEARANCE

The feature that allows you install the fireplace in a housing construction made of combustible materials.



INTEGRATED CONTROL PANEL

The FLA3 burner has an intuitive control panel with an LCD screen and inlet for automatic refuelling.

AUTOMATIC FLA3 BURNER

The automatic burner with the patented BEV Technology® is the most advanced product in the industry ensuring the cleanest burning process without any smoke, smell or ash. The flame is produced by combusting ethanol vapors and has no direct contact with the liquid fuel.

REMOTE CONTROL OPTIONS

Control the fire with the included remote, app on your smartphone or home automation system.



GLASS SCREEN

The dedicated toughened glass plate covers the flame making it stable and even.

Forma 1800 Room Divider

Burner model	FLA3 1490 (BEV Technology®)
Fuel tank capacity	8.6 L
Maximum burn time	11 hours
Maximum heat output	13.0 kW
Minimum room cubature	130 m ³
Flame height regulation	6 stages
Weight	98.9 kg
Fuel type	bioethanol 86 - 96,6%
Flue	not required
Air change rate	1 space volume per hour
Power supply	230 V
Finish	black powder coating
Materials	steel, galvanized steel, toughened glass
Application	for indoor use only

CONTROL OPTIONS



included



included



optional

'PLANIKA N-CONTROL' APP

Control the fire with your smartphone!



O-TL certified 

Manufactured to UL standards

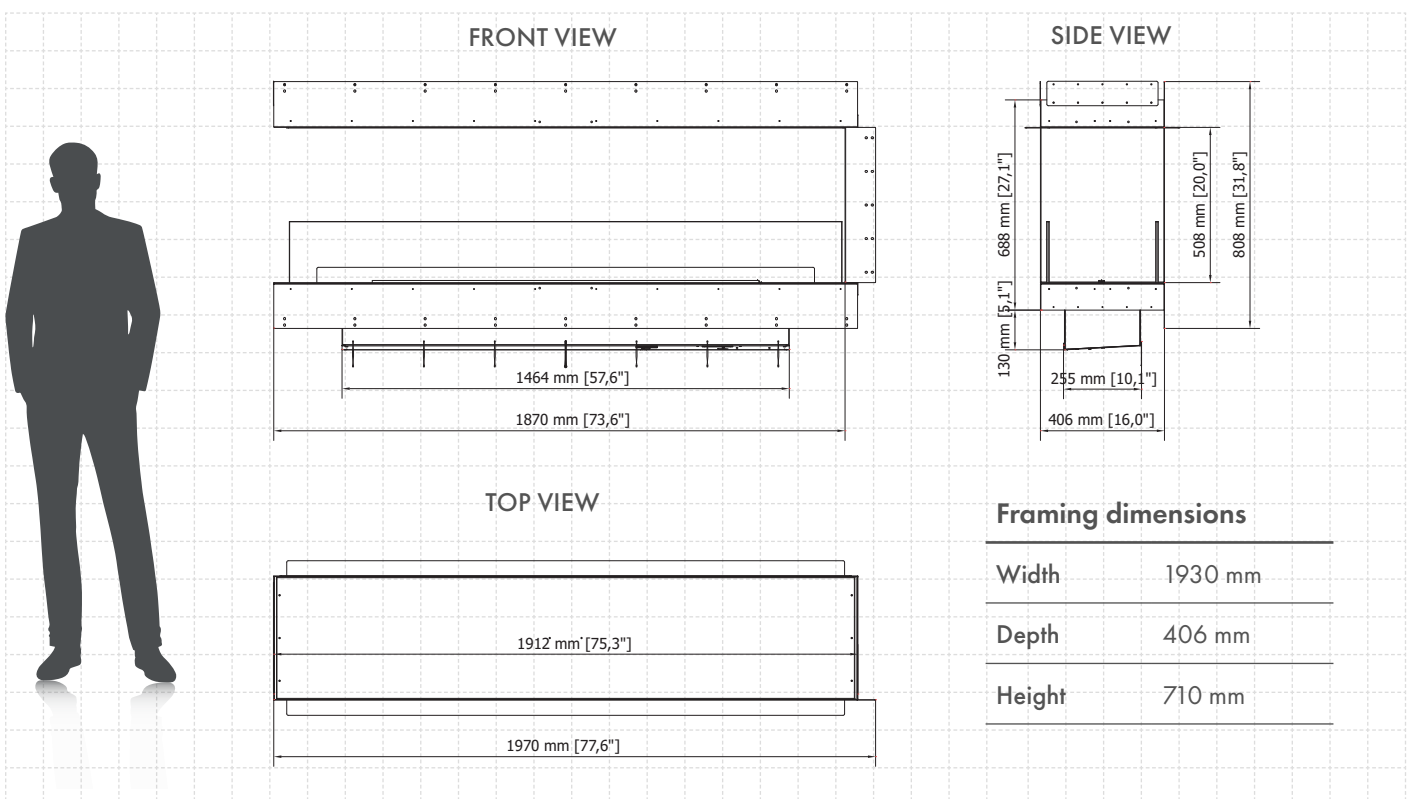

All product specifications and data are subject to change without notice and are believed to be accurate as of the date hereof. Planika Sp. z o.o., its affiliates, agents, and employees, and all persons acting on its or their behalf (collectively, "Planika Sp. z o.o."), disclaim any and all liability for any errors, inaccuracies or incompleteness contained in any document or in any other disclosure relating to any product. To the maximum extent permitted by applicable law, Planika Sp. z o.o. disclaims any and all liability arising out of the application or use of any product. This document does not expand or otherwise modify Planika Sp. z o.o.'s terms and conditions of purchase, including but not limited to the warranty expressed therein. No license, express or implied, by estoppel or otherwise, to any intellectual property rights is granted by this document or by any conduct of Planika Sp. z o.o.. Customers using or selling Planika Sp. z o.o.'s products not expressly indicated for use in such applications do so entirely at their own risk and agree to fully indemnify Planika Sp. z o.o. for any damages arising or resulting from such use or sale. The images are indicative only.

FORMA 2300 ROOM DIVIDER

WITH FLA3 1990 AUTOMATIC ETHANOL BURNER

BEV Technology®

PENINSULA FIREPLACE

A unique showstopper for contemporary living rooms or any other open concept interior. The peninsula fireplace breaks up the interior, creating two separate spaces with one fireplace.

PROTECTIVE DEFLECTOR

With the attached deflector you can cover the fireplace housing with combustible materials.

BEST BUILD QUALITY

The product passed extensive tests carried out by the leading certification institutes. It is manufactured according to UL standards and is O-TL certified, meeting the most demanding safety and quality requirements.

TRUE ZERO CLEARANCE

The feature that allows you install the fireplace in a housing construction made of combustible materials.



INTEGRATED CONTROL PANEL

The FLA3 burner has an intuitive control panel with an LCD screen and inlet for automatic refuelling.

AUTOMATIC FLA3 BURNER

The automatic burner with the patented BEV Technology® is the most advanced product in the industry ensuring the cleanest burning process without any smoke, smell or ash. The flame is produced by combusting ethanol vapors and has no direct contact with the liquid fuel.

REMOTE CONTROL OPTIONS

Control the fire with the included remote, app on your smartphone or home automation system.



GLASS SCREEN

The dedicated toughened glass plate covers the flame making it stable and even.

Forma 2300 Room Divider

Burner model	FLA3 1990 (BEV Technology®)
Fuel tank capacity	11.7 L
Maximum burn time	12 hours
Maximum heat output	18.0 kW
Minimum room cubature	180 m ³
Flame height regulation	6 stages
Weight	132.2 kg
Fuel type	bioethanol 86 - 96,6%
Flue	not required
Air change rate	1 space volume per hour
Power supply	230 V
Finish	black powder coating
Materials	steel, galvanized steel, toughened glass
Application	for indoor use only

CONTROL OPTIONS



included



included



optional

'PLANIKA N-CONTROL' APP

Control the fire with your smartphone!



O-TL certified 

Manufactured to UL standards

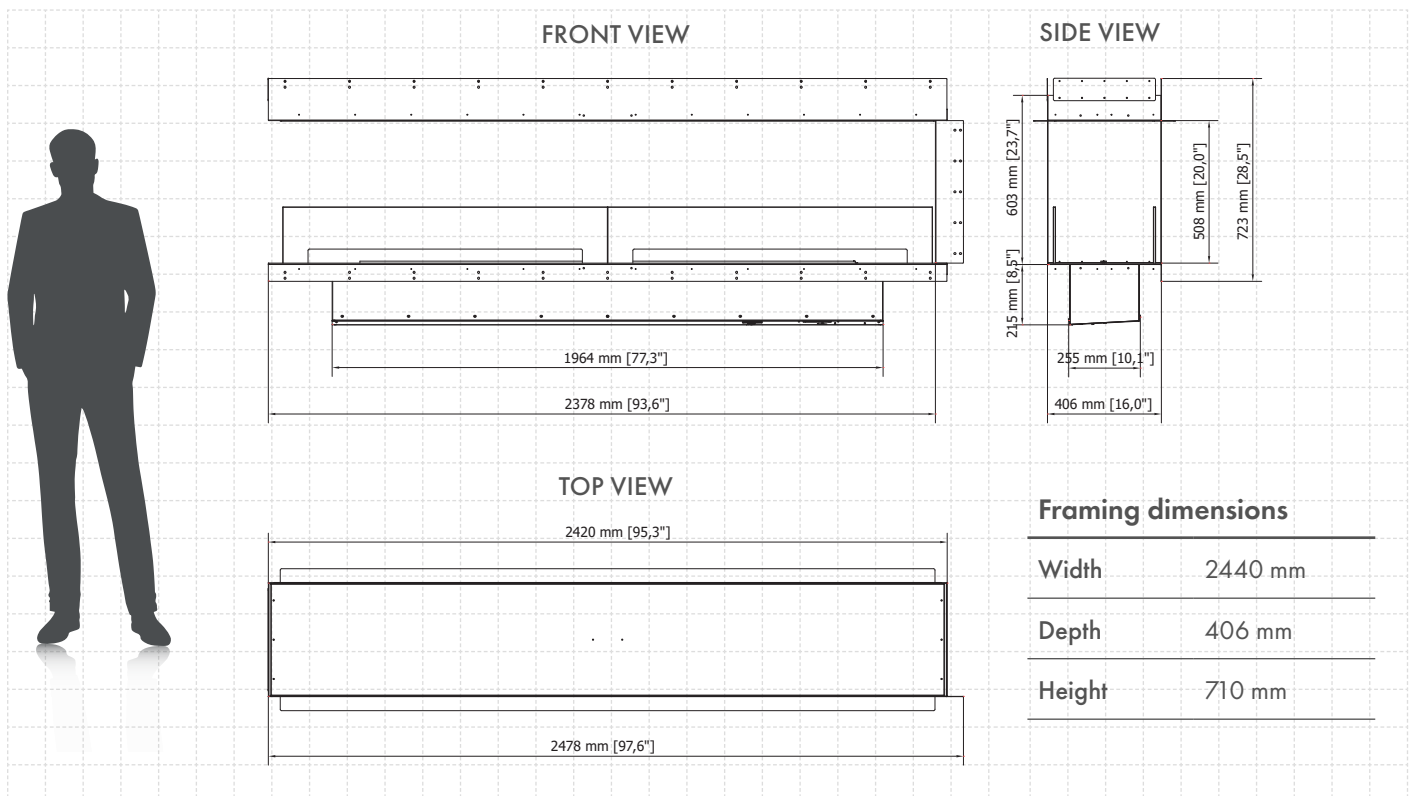

All product specifications and data are subject to change without notice and are believed to be accurate as of the date hereof. Planika Sp. z o.o., its affiliates, agents, and employees, and all persons acting on its or their behalf (collectively, "Planika Sp. z o.o."), disclaim any and all liability for any errors, inaccuracies or incompleteness contained in any document or in any other disclosure relating to any product. To the maximum extent permitted by applicable law, Planika Sp. z o.o. disclaims any and all liability arising out of the application or use of any product. This document does not expand or otherwise modify Planika Sp. z o.o.'s terms and conditions of purchase, including but not limited to the warranty expressed therein. No license, express or implied, by estoppel or otherwise, to any intellectual property rights is granted by this document or by any conduct of Planika Sp. z o.o.. Customers using or selling Planika Sp. z o.o.'s products not expressly indicated for use in such applications do so entirely at their own risk and agree to fully indemnify Planika Sp. z o.o. for any damages arising or resulting from such use or sale. The images are indicative only.

FORMA 2700 ROOM DIVIDER WITH FLA3 2490 AUTOMATIC ETHANOL BURNER

BEV Technology®

PENINSULA FIREPLACE

A unique showstopper for contemporary living rooms or any other open concept interior. The peninsula fireplace breaks up the interior, creating two separate spaces with one fireplace.

PROTECTIVE DEFLECTOR

With the attached deflector you can cover the fireplace housing with combustible materials.

BEST BUILD QUALITY

The product passed extensive tests carried out by the leading certification institutes. It is manufactured according to UL standards and is O-TL certified, meeting the most demanding safety and quality requirements.

TRUE ZERO CLEARANCE

The feature that allows you install the fireplace in a housing construction made of combustible materials.



INTEGRATED CONTROL PANEL

The FLA3 burner has an intuitive control panel with an LCD screen and inlet for automatic refuelling.

AUTOMATIC FLA3 BURNER

The automatic burner with the patented BEV Technology® is the most advanced product in the industry ensuring the cleanest burning process without any smoke, smell or ash. The flame is produced by combusting ethanol vapors and has no direct contact with the liquid fuel.

REMOTE CONTROL OPTIONS

Control the fire with the included remote, app on your smartphone or home automation system.

GLASS SCREEN

The dedicated toughened glass plate covers the flame making it stable and even.

Forma 2700 Room Divider

Burner model	FLA3 2490 (BEV Technology®)
Fuel tank capacity	14.8 L
Maximum burn time	12 hours
Maximum heat output	22.5 kW
Minimum room cubature	225 m ³
Flame height regulation	6 stages
Weight	199.0 kg
Fuel type	bioethanol 86 - 96,6%
Flue	not required
Air change rate	1 space volume per hour
Power supply	230 V
Finish	black powder coating
Materials	steel, galvanized steel, toughened glass
Application	for indoor use only

CONTROL OPTIONS



included



included



optional

'PLANIKA N-CONTROL' APP

Control the fire with your smartphone!

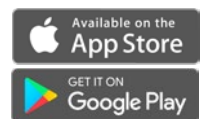

O-TL certified 

Manufactured to UL standards

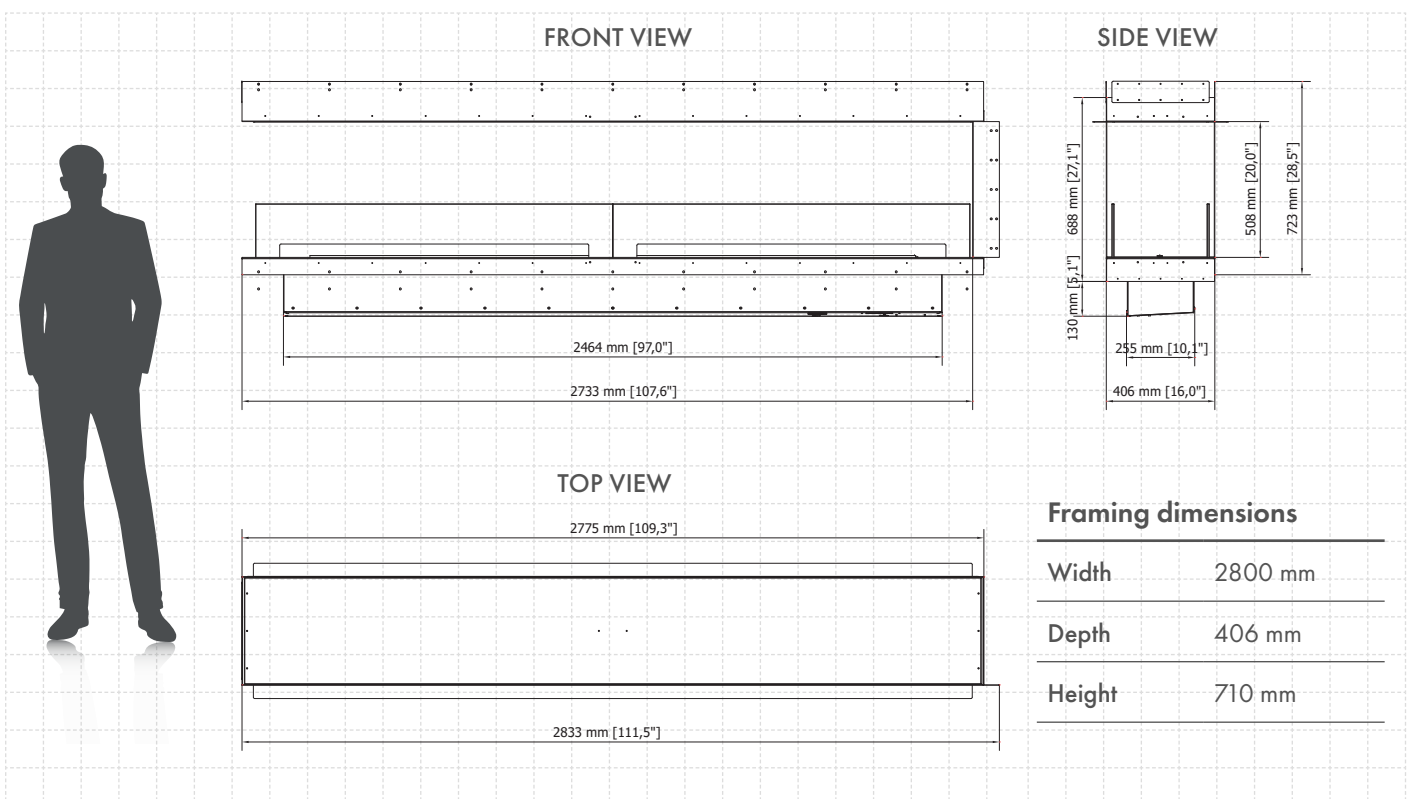

All product specifications and data are subject to change without notice and are believed to be accurate as of the date hereof. Planika Sp. z o.o., its affiliates, agents, and employees, and all persons acting on its or their behalf (collectively, "Planika Sp. z o.o."), disclaim any and all liability for any errors, inaccuracies or incompleteness contained in any document or in any other disclosure relating to any product. To the maximum extent permitted by applicable law, Planika Sp. z o.o. disclaims any and all liability arising out of the application or use of any product. This document does not expand or otherwise modify Planika Sp. z o.o.'s terms and conditions of purchase, including but not limited to the warranty expressed therein. No license, express or implied, by estoppel or otherwise, to any intellectual property rights is granted by this document or by any conduct of Planika Sp. z o.o.. Customers using or selling Planika Sp. z o.o.'s products not expressly indicated for use in such applications do so entirely at their own risk and agree to fully indemnify Planika Sp. z o.o. for any damages arising or resulting from such use or sale. The images are indicative only.