

Resident

Felix Chair

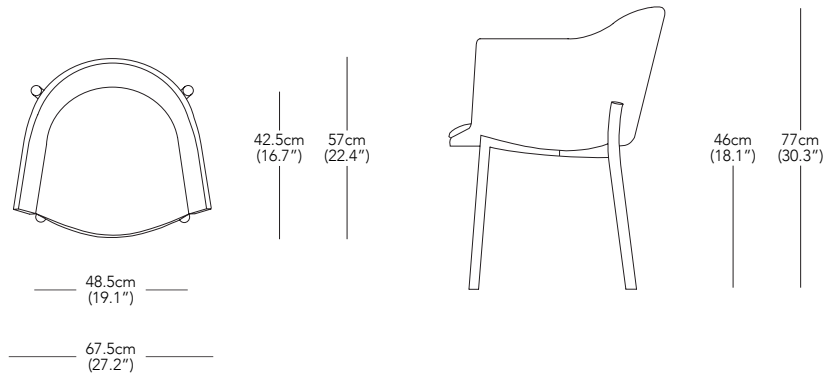

DESIGNER
Simon James / 2011

PRODUCT DESCRIPTION
Upholstered Chair

PRODUCT CODE
FEX001 - Felix Chair

* Components drawn in relative scale. Refer to CAD files for accurate drawings.

MATERIALS
Multi Density Foam, Timber & Steel Frame

PACKAGED DIMENSIONS
1 Box Per Chair

PRODUCT ENVIRONMENT
Indoor Use Only

W	D	H	Box		
68.5	x	58	x	78cm	0.31 m ³
27	x	22.8	x	30.7"	11.0 ft ³

APPROPRIATE FOR HARD CONTRACT USE
Yes

PACKAGED WEIGHT
11.6 kg
25.6 lbs

WARRANTY
3 Years

PRODUCT WEIGHT
8.6 kg
19.0 lbs

UPHOLSTERY OPTIONS
Maharam - Messenger
Maharam - Mode
Camira - Synergy
Camira - Mainline Flax
Kvadrat - Hallingdal 65
Sorensen - Shade
Sorensen - Royal Nubuck

PERFORMANCE
100,000 Martindale
100,000 Martindale
100,000 Martindale
50,000 Martindale
100,000 Martindale
-
-

MATERIAL COMPOSITION
78% Recycled Polyester, 15% Polyester, 7% Nylon
80% Recycled Polyester, 20% Polyester
95% Virgin Wool, 5% Polyamide
70% Virgin Wool, 30% Flax
70% New Wool, 30% Viscose
100% Full Protected Aniline Leather
100% Nubuck Aniline Leather

UPHOLSTERY USAGE
Fabric
1.8 m, 2 yd

Leather
3.1 m², 33 ft²

COUNTRY OF ORIGIN
Manufactured in sales territory - UK / USA / AUS / NZ