

AZTEC

Gerard van de Berg 1981/2019



ROMP

Frame

Houten constructie van beuken regels gecombineerd met multiplex plaat-materiaal.

Vering

No-sag veren.

Schuim

In de zitting met een natuurlijke valling worden drie verschillende kwaliteiten HR-schuim gebruikt. De basis is een zacht polyurethaan schuim (soortelijk gewicht 40kg/m³) voor het zit-comfort. Aan de voorkant is een stevige spie (soortelijk gewicht 45kg/m³) geplaatst voor een goede knieholte ondersteuning en voorkomt dat men uit de bank „glijdt“. Het geheel wordt met een superzachte schuim afgedekt. Het rug- en armgedeelte aan de binnenkant van de bank bestaat uit twee kwaliteiten HR-schuim. Het achterste gedeelte is een harder schuim. Het voorste gedeelte een zachter polyurethaan schuim. De resterende schuimdelen bestaan uit verschillende hardere en zachtere kwaliteiten polyether schuimkwaliteiten. Het geheel wordt afgedekt met een superzacht schuim-dek en 200 grams dacron.

STOFFERING

Stof of leer. De AZTEC is in het geval van een stoffen hoes geheel afneembaar. De leren hoezen worden vastgeniet. Stoffen moeten een minimale breedte (excl. zelfkant) van 1,35m hebben om te kunnen worden verwerkt op de AZTEC.

POTEN

Zwarte kunststof poten voorzien van een rubberen doppen.

BRANDVEILIG

De AZTEC banken zijn te verkrijgen in British Standard 5852, part 1 en 2, en CA, TB 117-2013

BODY

Frame

Wooden construction of beech rows combined with plywood plate material.

Suspension

No-sag springs.

Foam

Three different grades of HR foam are used in the naturally-sloping seat. The base is of soft polyurethane foam (specific weight 40 kg/m³) for sitting comfort. A sturdy spline (specific weight 45 kg/m³) is fitted at the front for good knee support and to prevent "sliding" off the couch. The whole unit is covered with an exceptionally soft foam. The back and arm section on the inside of the sofa consists of two grades of HR foam. The rear section is of harder foam. The front section is of softer poly-urethane foam. The remaining foam sections consist of various harder and softer grades of polyether foam grades. The whole unit is covered with an exceptionally soft foam cover and 200 grams of Dacron.

UPHOLSTERY

Fabric or leather. The AZTEC is completely removable in the case of a fabric cover. The leather covers are stapled. Fabrics must have a minimum width (excluding selvedge) of 1.35 m in order to be processed on the AZTEC.

LEGS

Black plastic legs with rubber caps.

FIREPROOF

The AZTEC sofas are available in British Standard 5852, part 1 and 2, and CA, TB 117-2013

KORPUS

Rahmen

Holzkonstruktion aus Buchenlatten und Multiplex-Platten.

Federung

Nosagfedern.

Schaumfüllung

Für die Sitzfläche mit einer natürlichen Neigung werden drei verschiedene Sorten HR-Schaum verarbeitet. Als Basis dient ein weicher PUR-Schaum mit einer Dichte von 40 kg/m³, der für den Sitzkomfort sorgt. Ein stabiler Keil (Dichte 45 kg/m³) an der Vorderseite unterstützt die Kniekehle und verhindert, dass man vom Sofa rutscht. Dies alles ist mit einem sehr weichen Schaum abgedeckt. Die Rücken- und Armlehnen an der Innenseite des Sofas bestehen aus zwei Sorten HR-Schaum. Im hinteren Bereich ist ein härterer Schaum verarbeitet und im vorderen Bereich ein weicherer PUR-Schaum. Die übrigen Schaumteile bestehen aus verschiedenen härteren oder weicheren Sorten PE-Schaum. Dies alles ist mit einer sehr weichen Schaumschicht und Dacron (200 g/m²) abgedeckt.

BEZUG

Stoff oder Leder. Der Stoff-bezug des AZTEC kann voll-ständig abgenommen werden. Die Lederbezüge werden festgenietet. Um die Stoffe auf dem AZTEC verarbeiten zu können, müssen sie eine Mindestbreite von 1,35 m zzgl. Webkante besitzen.

FÜSSE

Schwarze Kunststofffüße mit Gummikappen.

BRANDSCHUTZ

Die AZTEC-Sofas erfüllen die Normen BS 5852, Teil 1 und 2 sowie CA, TB 117-2013.

SCHOUDERKUSSEN

Het schouderkussen kan op elke rug van de AZTEC worden geplaatst. Door de anti-slip aan de onderkant en het gewicht wordt het kussen op zijn plaats gehouden. Afhankelijk van de stoffering op de bank kan het schouderkussen tijdens gebruik zich verplaatsen. Dat is onvermijdelijk. Het wordt daarom ook afgeraden om het schouderkussen op een leren bank of op hele gladde stoffen te gebruiken.

STOFFERING

Het schouderkussen is alleen in stof verkrijgbaar. Het kussen kan op twee manieren worden bekleed: met of zonder ribbels. De geribbelde versie heeft de beperking dat deze alleen gemaakt kan worden van de volgende stoffen:

Montis Aldo
Montis Allegra
Montis Amaro
Montis Bryna
Montis Fidal
Montis Mellow
Montis Orsetto
Kvadrat Sahco Baru
Kvadrat Gentle
Kvadrat Sahco Moss
Kvadrat Sahco Safire
De Ploeg Monza
De Ploeg Monza Melange

De stoffering is afneembaar. Hier-voor dient eerst de metalen onderplaat die voorzien is van anti-slip te worden losgeschroefd.

CONSTRUCTIE

Het schouderkussen is opgebouwd om een metalen frame met aan de zijkanten twee multiplex plaatjes. Daartussen is een HR schuim met een soortelijk gewicht van $55\text{kg}/\text{m}^3$ gebruikt. De stoffering is voorzien van een polyurethaan schuim en wordt bij de ribbelvariant door-gestikt. Aan de onderzijde is een metalen plaat voorzien van anti-slip materiaal vastgeschroefd.

SHOULDER CUSHION

The shoulder cushion can be placed on any back of the AZTEC. The anti-slip underside and the weight keeps the cushion in place. Depending on the upholstery on the sofa, the shoulder cushion can move during use. This is unavoidable. It is therefore not recommended to use the shoulder cushion on a leather sofa or on very smooth fabrics.

UPHOLSTERY

The shoulder cushion is only produced in fabric. The cushion can be upholstered in two ways: with or without ribbing. For the ribbed version, there is the restriction that it can only be made in the following fabrics:

Montis Aldo
Montis Allegra
Montis Amaro
Montis Bryna
Montis Fidal
Montis Mellow
Montis Orsetto
Kvadrat Sahco Baru
Kvadrat Gentle
Kvadrat Sahco Moss
Kvadrat Sahco Safire
De Ploeg Monza
De Ploeg Monza Melange

The upholstery is removable. To remove the upholstery, first un-screw the metal bottom plate, which is provided with anti-slip coating.

CONSTRUCTION

The shoulder cushion is built around a metal frame with two plywood plates on the sides. In between HR foam with a specific weight of $55\text{kg}/\text{m}^3$ is used. The upholstery is made of polyurethane foam and is quilted in the ribbed version. A metal plate with non-slip material is screwed to the underside.

SCHULTERKISSEN

Das Schulterkissen kann auf jeder Rückseite des AZTEC angebracht werden. Die rutschfeste Unterseite und das Gewicht halten das Kissen an seinem Platz. Je nach Polsterung des Sofas kann sich das Schulterkissen während der Benutzung bewegen. Dies ist unvermeidlich. Es wird daher nicht empfohlen, das Schulterkissen auf einem Ledersofa oder auf sehr glatten Stoffen zu verwenden.

POLSTERMÖBEL

Das Schulterkissen wird nur in Stoff hergestellt. Das Kissen kann auf zwei Arten gepolstert werden: mit oder ohne Rippung. Für die gerippte Version gilt die Einschränkung, dass sie nur aus den folgenden Stoffen hergestellt werden kann:

Montis Aldo
Montis Allegra
Montis Amaro
Montis Bryna
Montis Fidal
Montis Mellow
Montis Orsetto
Kvadrat Sahco Baru
Kvadrat Gentle
Kvadrat Sahco Moss
Kvadrat Sahco Safire
De Ploeg Monza
De Ploeg Monza Melange

Die Polsterung sind abnehmbar. Dazu muss die Bodenplatte aus Metall, die mit einer rutschfesten Unterlage versehen ist, zunächst abgeschraubt werden.

KONSTRUKTION

Das Schulterkissen ist um einen Metallrahmen mit zwei Sperrholzplatten an den Seiten aufgebaut. Dazwischen wird HR-Schaum mit einem spezifischen Gewicht von $55\text{kg}/\text{m}^3$ verwendet. Die Polsterung besteht aus Polyurethanschaum und ist in der gerippten Version gesteppt. An der Unterseite ist eine Metallplatte mit rutschfestem Material angeschraubt.

AZTEC

Gerard van de Berg 1981/2019



AZTEC

Gerard van de Berg 1981/2019



AZTEC

Gerard van de Berg 1981/2019



plain shoulder cushion



ribbed shoulder cushion

AZTEC

Gerard van de Berg 1981/2019



AZTEC

Gerard van de Berg 1981/2019

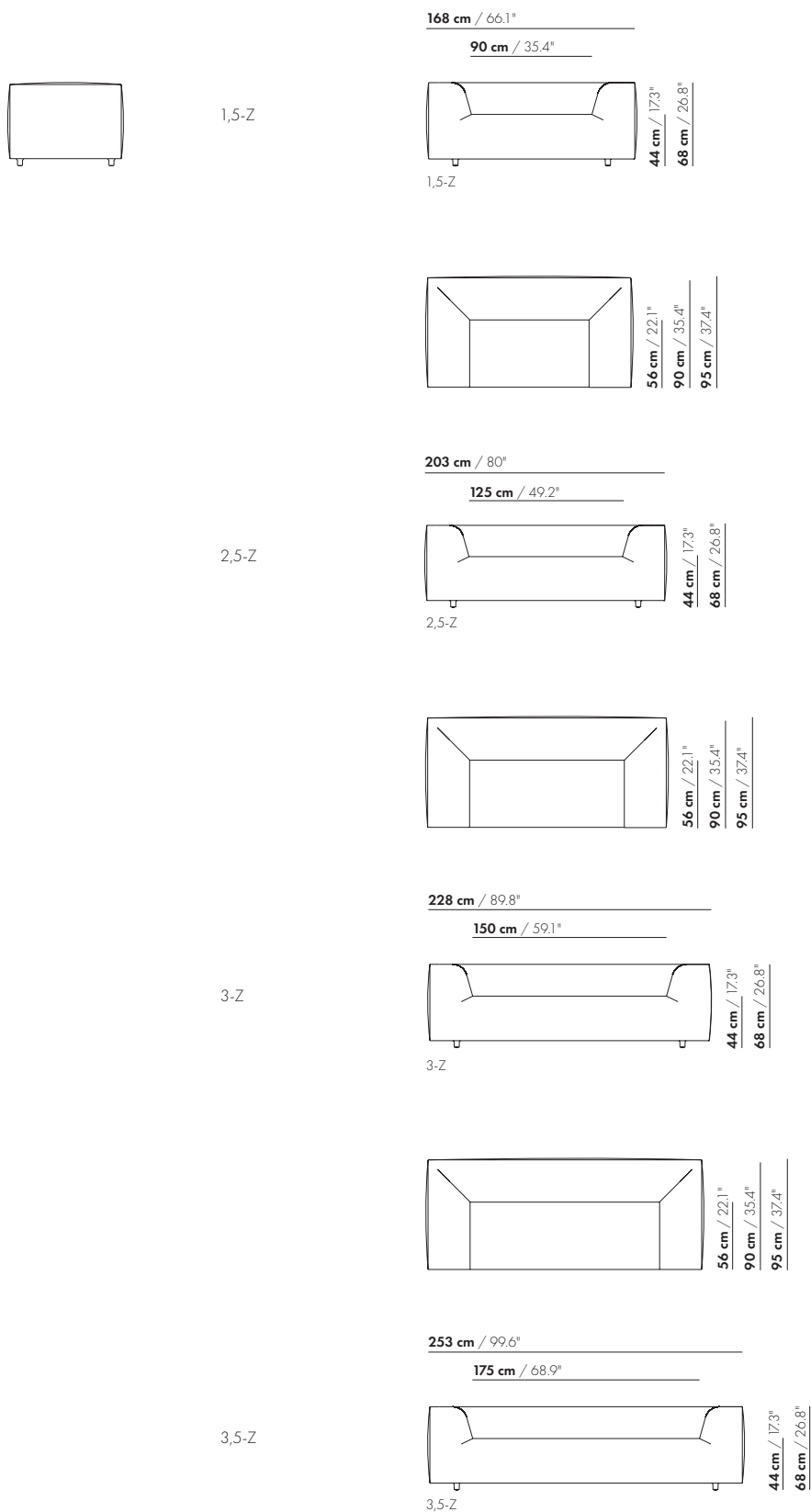

AZTEC

Gerard van de Berg 1981/2019

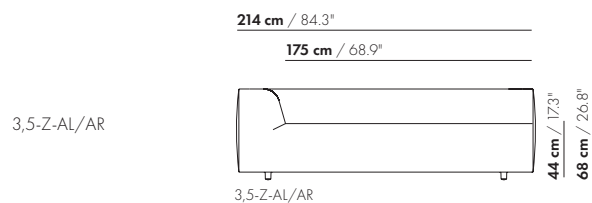
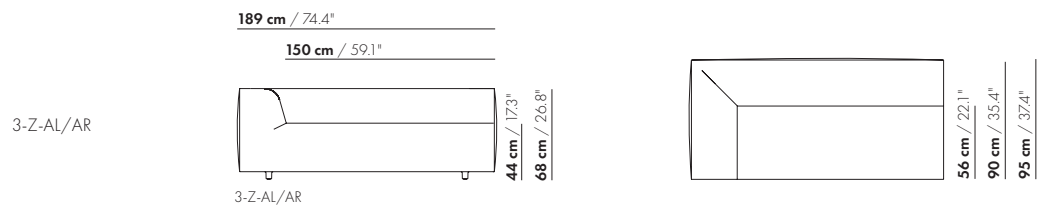
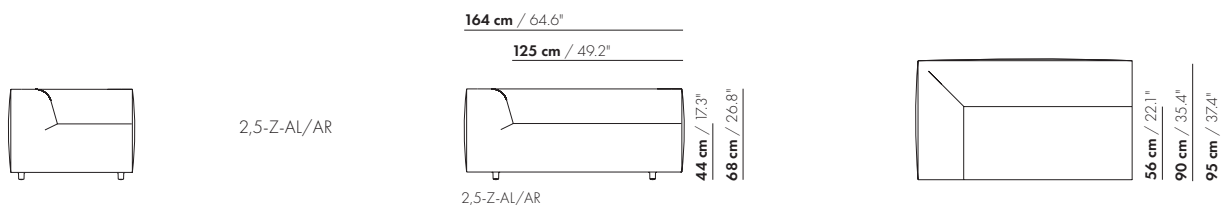
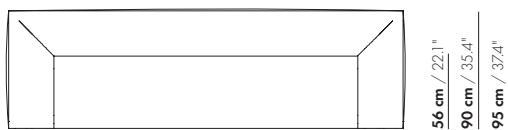
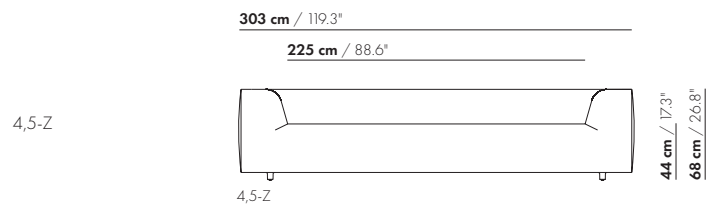
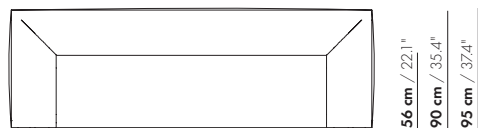
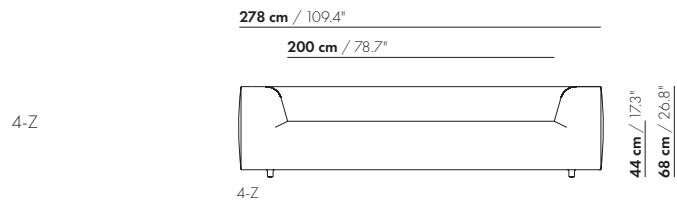

AZTEC

Gerard van de Berg 1981/2019

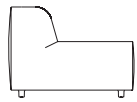

1,5-Z-ZA

90 cm / 35.4"

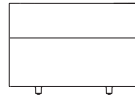

1,5-Z-ZA



56 cm / 22.1"
90 cm / 35.4"
95 cm / 37.4"

2,5-Z-ZA

125 cm / 49.2"

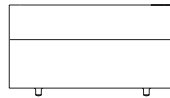

2,5-Z-ZA



56 cm / 22.1"
90 cm / 35.4"
95 cm / 37.4"

3-Z-ZA

150 cm / 59.1"

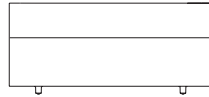

3-Z-ZA

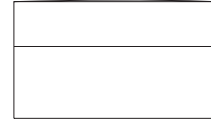

56 cm / 22.1"
90 cm / 35.4"
95 cm / 37.4"

3,5-Z-ZA

175 cm / 68.9"

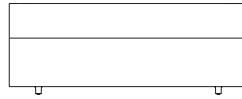

3,5-Z-ZA

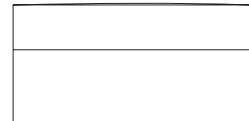

56 cm / 22.1"
90 cm / 35.4"
95 cm / 37.4"



P-60X90



P-60X90

44 cm / 17.3"

95 cm / 37.4"

90 cm / 35.4"



60 cm / 23.6"
65 cm / 25.6"

P-90X90



P-90X90

44 cm / 17.3"

95 cm / 37.4"

90 cm / 35.4"



90 cm / 35.4"
95 cm / 37.4"

AZTEC

Gerard van de Berg 1981/2019

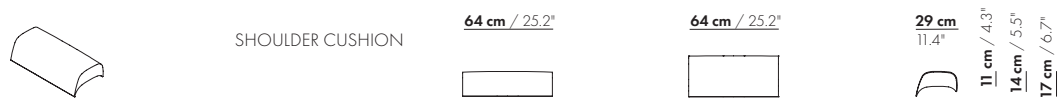
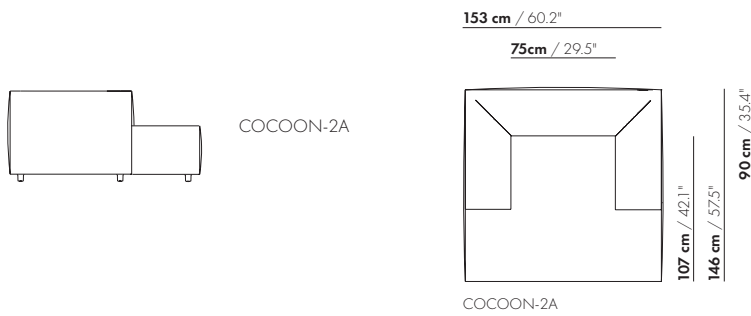
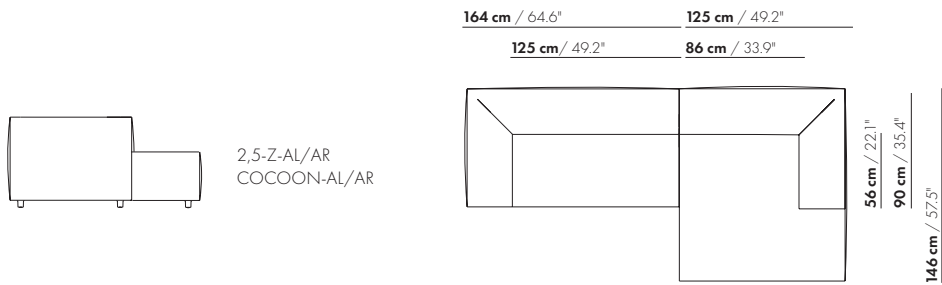
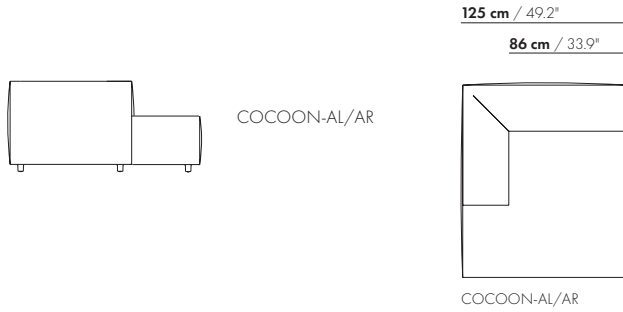

AZTEC

Gerard van de Berg 1981/2019

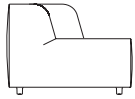

H-30-L/R

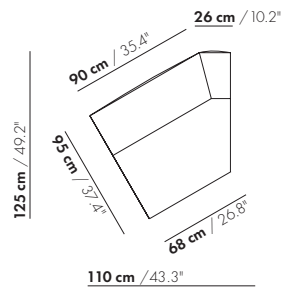

H-30-L

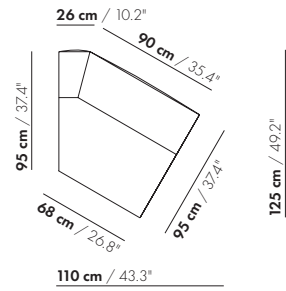

H-30-R

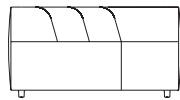

H-CLOSED-90

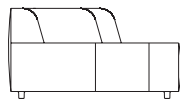
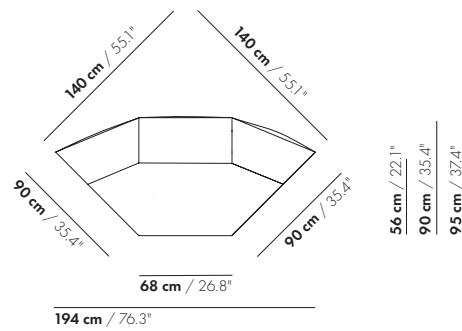

H-OPEN-90

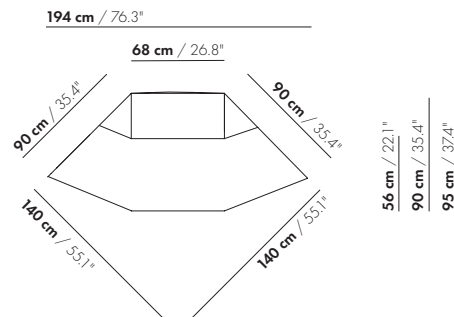

AZTEC XL

Gerard van de Berg 1981/2019



1,5-Z

168 cm / 66.1"
90 cm / 35.4"

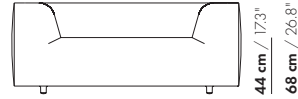

1,5-Z

44 cm / 17.3"
68 cm / 26.8"

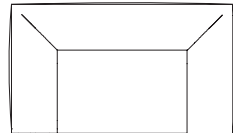

64 cm / 25.2"
98 cm / 38.6"
103 cm / 40.5"

203 cm / 80"
125 cm / 49.2"

2,5-Z

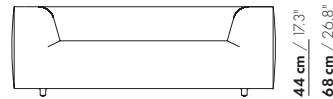

2,5-Z

44 cm / 17.3"
68 cm / 26.8"

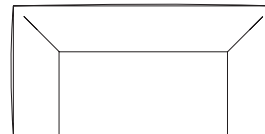

64 cm / 25.2"
98 cm / 38.6"
103 cm / 40.5"

228 cm / 89.8"
150 cm / 59.1"

3-Z

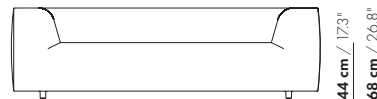

3-Z

44 cm / 17.3"
68 cm / 26.8"

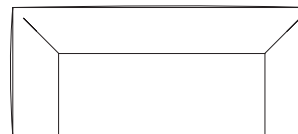

64 cm / 25.2"
98 cm / 38.6"
103 cm / 40.5"

253 cm / 99.6"
175 cm / 68.9"

3,5-Z

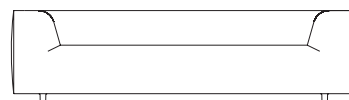

3,5-Z

44 cm / 17.3"
68 cm / 26.8"

AZTEC XL

Gerard van de Berg 1981/2019

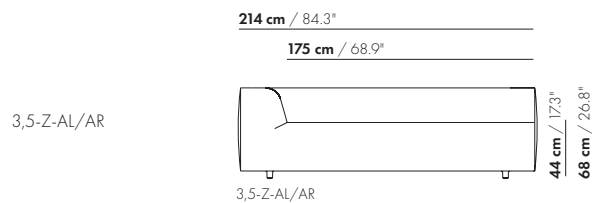
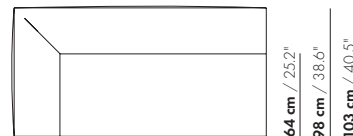
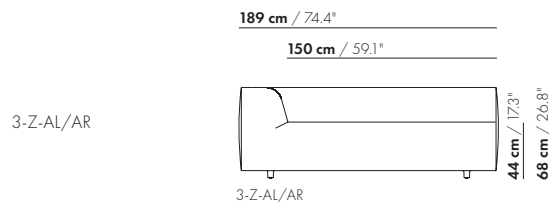
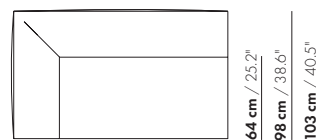
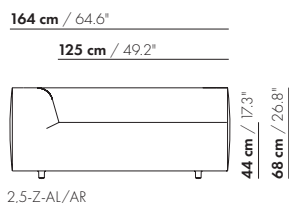
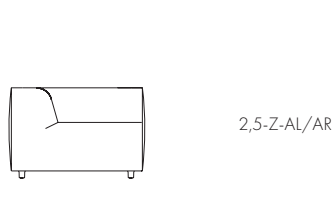
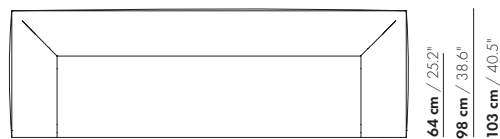
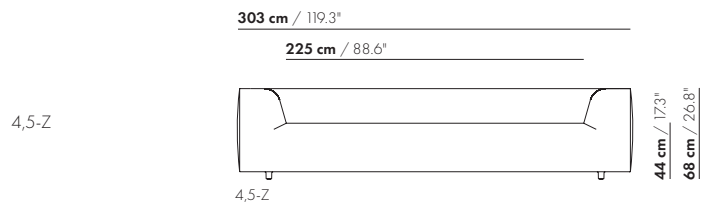
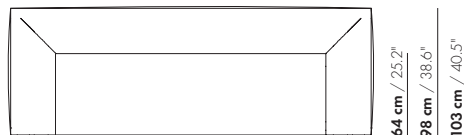
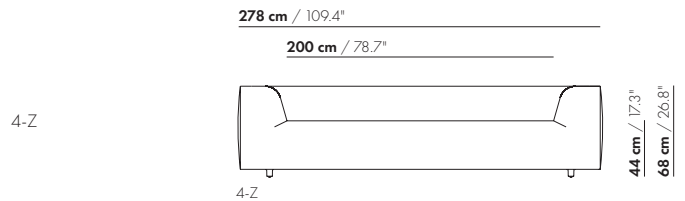

AZTEC XL

Gerard van de Berg 1981/2019

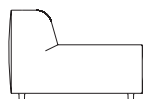

1,5-Z-ZA

90 cm / 35.4"

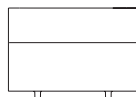

1,5-Z-ZA

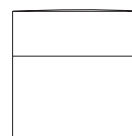

64 cm / 25.2"

98 cm / 38.6"

103 cm / 40.5"

2,5-Z-ZA

125 cm / 49.2"

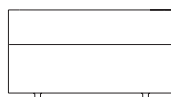

2,5-Z-ZA

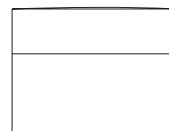

64 cm / 25.2"

98 cm / 38.6"

103 cm / 40.5"

3-Z-ZA

150 cm / 59.1"

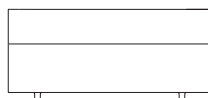

3-Z-ZA

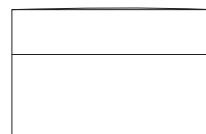

64 cm / 25.2"

98 cm / 38.6"

103 cm / 40.5"

3,5-Z-ZA

175 cm / 68.9"

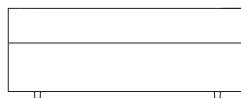

3,5-Z-ZA

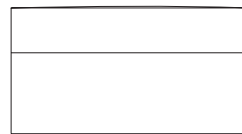

64 cm / 25.2"

98 cm / 38.6"

103 cm / 40.5"



P-60X98



P-60X98

44 cm / 17.3"

98 cm / 38.6"

103 cm / 40.5"



60 cm / 23.6"

65 cm / 25.6"

P-98X98

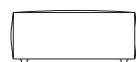

P-98X98

44 cm / 17.3"

98 cm / 38.6"

103 cm / 40.5"

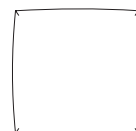

98 cm / 38.6"

103 cm / 40.5"

AZTEC XL

Gerard van de Berg 1981/2019

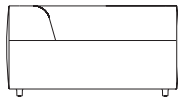

CHL-AL/AR

125 cm / 49.2"
86 cm / 33.9"

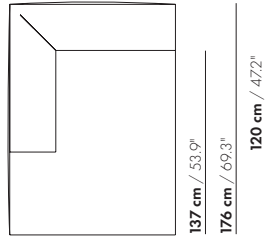

CHL-AL/AR

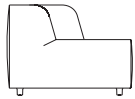

H-30-L/R

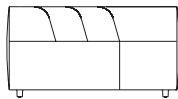
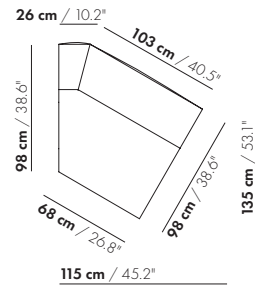
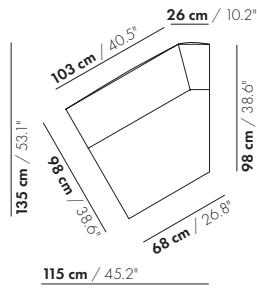

H-CLOSED-90

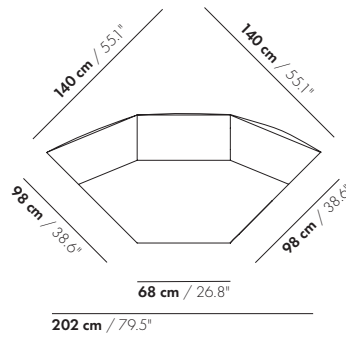

64 cm / 25.2"
98 cm / 38.6"
103 cm / 40.5"

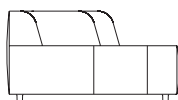

H-OPEN-90

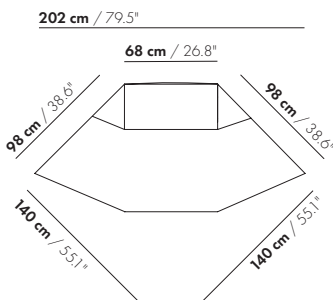

64 cm / 25.2"
98 cm / 38.6"
103 cm / 40.5"

stof- en leercollectie

MONTIS COLLECTIE	PRIJSKLASSE	SAMENSTELLING	LICHTECHTHEID	MARTINDALE
ALDO	S20	30% viscose, 25% katoen, 20% wol, 20% polyetheen, 20% polyacryl	5-7	50.000
ALLEGRA	S20	40% katoen, 22% polyacryl, 16% viscose, 11% wol, 11% polyamide	4-5	30.000
AMARO	S20	34% viscose, 33% polyacryl, 17% wol, 8% polyester, 4% linnen, 4% cotton	4-5	50.000
BRISTI	S20	63% acryl, 20% polyester, 17% katoen	5	40.000
BRYNA	S20	70% polyacryl, 18% polyetheen, 10% katoen, 2% ander vezels	4-5	40.000
BURANO	S30	100% Trevira CS	>5	150.000
ESOPO	S10	33% polyacryl, 25% viscose, 17% wol, 14% polyetheen, 11% katoen	4-5	30.000
FERRARA	S20	47% polyacryl, 19% wol, 16% polyacryl, 15% katoen, 3% nylon	4-5	30.000
FIDAL	S20	40% wol, 25% viscose, 25% katoen, 5% polyamide, 5% polyester	5-6	40.000
KARO	S20	53% polyacryl, 24% katoen, 10% linnen, 7% polyetheen, 6% viscose	4-5	28.000
LOCARNO	S20	58% viscose, 26% polyacryl, 7% linnen, 7% polyester, 2% zijde	4-5	30.000
MELLOW	S10	50% acryl, 23% katoen, 9% linnen, 9% polyester, 9% viscose	4-5	30.000
MILLER	S30	53% polyacryl, 27% viscose, 20% katoen	5	20.000
MORENA	S20	50% polyacryl, 20% linnen, 19% katoen, 8% nylon	4-5	40.000
NATURE	S20	70% wol, 25% katoen, 5% polyester	5-6	100.000
ORSETTO	S20	34% viscose, 33% polyacryl, 17% wol, 8% polyetheen, 4% linnen, 4% katoen	5	80.000
SIAM	S30	50% viscose, 26% linnen, 23% katoen, 1% polyamide	5	60.000
STRADA	S20	92% katoen BCI, 8% gerecycled katoen	5	50.000
TIKO	S30	36% viscose, 25% linnen, 19% katoen, 18% polyacryl, 2% polyamide	5-6	30.000
VITA	S30	55% viscose, 29% katoen, 16% linnen	5	30.000

MONTIS COLLECTIE LEER	PRIJSKLASSE	SOORT LEDER	LICHTECHTHEID	DIKTE
COUNTRY	L50	Aniline leder	3	1.4-1.6 mm
CUBA	L30	Aniline leder	3	1.0-1.2 mm
DORO	L40	Aniline leder	3	2.0-2.2 mm
MYRA	L20	Semi-aniline leder	4-5	1.0-1.2 mm
NABUK	L40	Aniline leder	3	1.3-1.5 mm
NOVARA	L30	Aniline leder, licht gepolijst	3	2.0-2.2 mm
RANCHO	L40	Aniline leder	3	1.4-1.6 mm
TOBAGO	L20	Aniline afgewerkt leder	3	1.2-1.4 mm
TRINIDAD	L50	Aniline leder	3	2.0-2.2 mm

LEER COLLECTIE DERDEN	PRIJSKLASSE	SOORT LEDER	LICHTECHTHEID	DIKTE
BOX LAND	L20	Geprent gepigmenteerd	>5	1.4-1.6 mm
ELMOFOT	L40	Semi-aniline leder	6	1.0-1.3 mm
PANAMA	L20	Geprent gepigmenteerd	6	1.0-1.2 mm

DE PLOEG	PRIJSKLASSE	SAMENSTELLING	LICHTECHTHEID	MARTINDALE
ALMA	S10	100% polyester	6	70.000
ALTO	S30	36% scheerwol, 22% polyetheen, 7% katoen,	7	80.000
BIRK	S30	30% polyethyleen, 20% katoen, 20% viscose, 15% polyacryl, 15% linnen	5-6	20.000
BOLD	S50	70% scheerwol, 25% polyester, 5% pa front, 100% pes backing	5	20.000
KREDA	S30	35% polyacryl, 23% viscose, 20% polyester, 11% katoen, 11% linnen	5-6	100.000
MONZA	S30	12% polyester, 16% wol, 20% rayon, 24% katoen, 28% acryl	5-7	80.000
MONZA MELANGE	S30	12% polyester, 16% wol, 20% rayon, 24% katoen, 28% acryl	5-7	80.000
MOSS	S20	10% katoen, 15% polyetheen, 30% viscose, 40% acryl, 5% zijde	5	60.000
NUBIS	S30	45% polyester, 40% polyacryl, 11% katoen, 2% polyamide, 2% wol	7	100.000
OLIVE	S20	100% polyester	6	100.000
PANAMA	S40	100% scheerwol	5-6	60.000
PANAMA PLUS	S40	10% katoen, 10% polyester, 80% scheerwol	5-6	90.000
PLOEGWOOL	S40	100% scheerwol	6	90.000
PRAIRIE	S30	40% viscose 30% polyester, 25% katoen, 5% polyamide	5-6	90.000
RENO	S10	15% Katoen, 85% polyester	5-6	45.000
SERRA	S30	15% linnen, 15% katoen, 20% polyester, 5% viscose, 40% polyacryl, 5% polyamide	6-7	70.000

DE PLOEG	PRIJSKLASSE	SAMENSTELLING	LICHTECHTHEID	MARTINDALE
STEPPE	S30	57% scheerwol, 38% polyester, 5% polyamide	5-6	90.000
TWINWOOL	S40	70% scheerwol, 30% bionisch gerecycled	5-6	100.000
UMBRA	S30	51% acryl, 24% viscose, 14% katoen, 8% polyester, 3% andere vezels	6-7	100.000
VIVID	S10	100% polyester	5-6	40.000
KVADRAT	PRIJSKLASSE	SAMENSTELLING	LICHTECHTHEID	MARTINDALE
CANVAS 2	S40	90% scheerwol, 10% nylon	6	100.000
CODA 2	S50 + 5%	90% scheerwol, 10% nylon	6-7	100.000
DIVINA 3	S40	100% scheerwol	7	45.000
DIVINA MD	S40	100% scheerwol	8	45.000
DIVINA MELANGE 3	S40	100% scheerwol	9	45.000
FIORD 2	S40	92% scheerwol, 8% nylon	6	60.000
HALLINGDAL 65	S40	70% scheerwol, 30% viscose	7	100.000
MAPLE	S10	81% viscose, 15% linnen, 4% polyester	5-7	30.000
REMIX 3	S20	90% scheerwol, 10% nylon	5	100.000
RE-WOOL	S30	45% scheerwol, 45% gerecycleerde wol, 10% nylon	7	50.000
SABI	S40	65% scheerwol (kamgaren) 23% gerecycleerde wol 12% nylon	5-7	80.000
SAVANNA	S30	34% polyester 31% scheerwol 26%, acryl 4% katoen, 3% nylon, 2% linnen	6-7	45.000
STEELCUT 2	S40	90% scheerwol, 10% nylon	6-7	80.000
STEELCUT QUARTET	S40	90% scheerwol, 10% nylon	6-7	80.000
STEELCUT TRIO	S40	90% scheerwol, 10% nylon	6-7	100.000
TONICA 2	S40	100% scheerwol	7	45.000
KVADRAT / FEBRIK	PRIJSKLASSE	SAMENSTELLING	LICHTECHTHEID	MARTINDALE
APPAREL	S50	21% wol, 11% polyamide, 7% polyester, 1% elastaan, 60% polyester vulling	6-7	100.000
MIZMAZE	S40	60% polyester, 30% wol 10% nylon	6	100.000
MOSAIC 2	S40	46% polyester vulling, 27% wol, 12% polyester, 9% polyamide, 6% elastane	6-7	100.000
SPRINKLES	S40	40% polyester vulling, 30% wol, 20% polyester, 10% polyamide	7	60.000
KVADRAT / RAF SIMONS	PRIJSKLASSE	SAMENSTELLING	LICHTECHTHEID	MARTINDALE
SUNNIVA 3	S40	58% scheerwol, 25% viscose, 8% linnen, 5% nylon, 4% polyester	5-6	50.000
VANIR	S50 + 5%	90% scheerwol, 8% nylon	6-7	100.000
VIDAR 4	S50 + 5%	94% scheerwol, 6% nylon	5-6	100.000
KVADRAT / SAHCO	PRIJSKLASSE	SAMENSTELLING	LICHTECHTHEID	MARTINDALE
BALBOA	S50	100% polyester FR	5-6	100.000
BARU	S50 + 5%	87% wol, 10% polyester, 3% polyamide	4-5	65.000
FEZ	S50 + 5%	83% katoen, 15% polyester, 2% viscose	5-6	60.000
MOSS	S30	52% katoen, 22% viscose, 14% polyacryl, 6% linnen, 3% polyester, 3% nylon	5-7	50.000
SAFIRE	S30	43% viscose, 17% polyacryl, 15% scheerwol, 9% katoen, 8% polyester/linnen	5-6	44.000
ZERO	S40	65% katoen, 20% polyacryl 15% polyester	5-6	70.000
ROHI	PRIJSKLASSE	SAMENSTELLING	LICHTECHTHEID	MARTINDALE
CLEO	S40	95% scheerwol, 5% polyamide	5-8	70.000
CREDO	S30	95% scheerwol, 5% polyamide	5-8	110.000
MICA	S30	95% scheerwol, 5% polyamide	5-8	70.000
NOVUM	S40	96% scheerwol, 4% polyamide	5-8	90.000
OPERA	S40	96% scheerwol, 4% polyamide	5-8	90.000
SERA	S30	94% scheerwol, 6% polyamide	5-8	122.000
TOPIA	S30	95% scheerwol, 5% polyamide	5-8	50.000
ZIMMER & ROHDE	PRIJSKLASSE	SAMENSTELLING	LICHTECHTHEID	MARTINDALE
INFINITY PLUS VELVET	S40	100% polyester	6	100.000
INFINITY LINEN LOOK	S40	74% acryl, 26% polyester,	6	30.000
INFINITY COTTON FEEL	S40	100% acryl	5	50.000

Indien u kiest voor een materiaal dat niet in ons overzicht vermeld staat, betreft het een ingezonden bekleding.

stoffen en leer op soort



STOFFEN COLLECTIE MONTIS	PRIJSKLASSE
ALDO	S20
ALLEGRA	S20
AMARO	S20
BRISTI	S20
BRYNA	S20
BURANO	S30
ESOPO	S10
FERRARA	S20
FIDAL	S20
KARO	S20
LOCARNO	S20
MELLOW	S10
MILLER	S30
MORENA	S20
NATURE	S20
ORSETTO	S20
SIAM	S30
STRADA	S20
TIKO	S30
VITA	S30

LEER COLLECTIE MONTIS	PRIJSKLASSE
COUNTRY	L50
CUBA	L30
DORO	L40
MYRA	L20
NABUK	L40
NOVARA	L30
RANCHO	L40
TOBAGO	L20
TRINIDAD	L50

LEER COLLECTIE DERDEN	PRIJSKLASSE
BOX LAND	L20
ELMOSOFT	L40
PANAMA	L20

DE PLOEG	PRIJSKLASSE
ALMA	S10
ALTO	S30
BIRK	S30
BOLD	S50
KREDA	S30
MONZA	S30
MONZA MELANGE	S30
MOSS	S20
NUBIS	S30
OLIVE	S20
PANAMA	S40
PANAMA PLUS	S40
PLOEGWOOL	S40
PRAIRIE	S30
RENO	S10
SERRA	S30
STEPPE	S30
TWINWOOL	S40

DE PLOEG	PRIJSKLASSE
UMBRA	S30
VIVID	S10

KVADRAT	PRIJSKLASSE
CANVAS 2	S40
CODA 2	S50 + 5%
DIVINA 3	S40
DIVINA MD	S40
DIVINA MELANGE 3	S40
FIORD 2	S40
HALLINGDAL 65	S40
MAPLE	S10
REMIX 3	S20
RE-WOOL	S30
SABI	S40
SAVANNA	S30
STEELCUT 2	S40
STEELCUT QUARTET	S40
STEELCUT TRIO	S40
TONICA 2	S40

KVADRAT / FEBRIK	PRIJSKLASSE
APPAREL	S50
MIZMAZE	S40
MOSAIC 2	S40
SPRINKLES	S40

KVADRAT / RAF SIMONS	PRIJSKLASSE
SUNNIVA 3	S40
VANIR	S50 + 5%
VIDAR 4	S50 + 5%

KVADRAT / SAHCO	PRIJSKLASSE
BALBOA	S50
BARU	S50 + 5%
FEZ	S50 + 5%
MOSS	S30
SAFIRE	S30
ZERO	S40

ROHI	PRIJSKLASSE
CLEO	S40
CREDO	S30
MICA	S30
NOVUM	S40
OPERA	S40
SERA	S30
TOPIA	S30

ZIMMER & ROHDE	PRIJSKLASSE
INFINITY PLUS VELVET	S40
INFINITY LINEN LOOK	S40
INFINITY COTTON FEEL	S40

Indien u kiest voor een materiaal dat niet in ons overzicht vermeld staat, betreft het een ingezonden bekleding.