

**THONET**

LOUNGE  
CHAIR  
808/809



DESIGN  
FORMSTELLE







DE Mit dem Programm 808 hat das Münchner Designstudio Formstelle einen Lounge-Sessel entwickelt, der maximalen Komfort mit zahlreichen Möglichkeiten zur Individualisierung verbindet. Der Lounge-Sessel 808 spielt mit dem Kontrast zwischen schützender Hülle und Offenheit. In seiner Umgebung bietet er einen Ort des Rückzugs und der Ruhe. Seine charakteristische Anmutung entsteht durch eine konsequente Neuinterpretation des klassischen Ohrensessels – das obere Rückenteil erinnert an einen schützenden Kragen. Die Schale umfängt den Sitzenden und vermittelt Geborgenheit. Das zweite markante Merkmal ist die bequeme, an Wellen erinnernde Polsterung. Der innere weiche Kern mit der lockeren Kissenoptik steht im spannungsvollen Gegensatz zur äußeren Schale. Schließlich ermöglicht eine intelligente Verstellmechanik dem Nutzer die individuelle Anpassung des Sessels.

Der kompakte Lounge-Sessel 809 ist der „kleine Bruder“ des erfolgreichen Lounge-Sessels 808 und fungiert als Rückzugsort in kleineren Räumen sowie in der Gruppe, in Kombination mit dem größeren Sessel oder den niedrigen Beistelltischen 1808 und 1809. Das Programm wird durch einen Fußhocker abgerundet.

EN With the range 808, Munich based design studio Formstelle has created a lounge chair that combines maximum comfort with numerous possibilities for individualisation. The lounge chair 808 plays with the contrast between a protective shell and an inviting openness, creating a place of retreat and calm. Its distinctive appearance is created through a contemporary reinterpretation of the classic wing chair – the shape suggests an elegant cocoon that embraces the person sitting in the chair and communicates a feeling of security. Another striking characteristic is the comfortable upholstery with its welcoming soft wave effect. This inner cushioned core establishes an intriguing contrast with the angularity of the outer shell. A clever mechanism allows users to individually adjust the position of the chair.

The compact lounge chair 809 functions as a “small brother” of the successful lounge chair 808, and as a place of retreat in smaller rooms or in groups, and in combination with the larger chair or the low side tables 1808 and 1809. A footstool rounds off the range.



**809, 1809 1808 UND/AND 808**  
 GESTELLE FLACHSTAHL EDELSTAHL OPTIK,  
 POLSTERUNG, PLATTEN EICHE KLAR LACKIERT/  
 FRAMES FLAT STEEL STAINLESS STEEL DESIGN,  
 UPHOLSTERY, TABLETOPS OAK CLEAR LACQUERED



DE Claudia Kleine, (geboren 1974 in München) und Jörg Kürschner (geboren 1969 in Karlsruhe, Schreiner und Möbelrestaurator) absolvierten an der Akademie der bildenden Künste in München den Studiengang Innenarchitektur. 2001 gründeten sie ebenfalls in München das Büro Formstelle, das Gestaltungsaufgaben aus den Bereichen Produktdesign, Innenarchitektur und Corporate Identity gestaltet. Für das Design-Duo spielen übergeordnete räumliche und inhaltliche Zusammenhänge eine wichtige Rolle. Die Produktgestaltung ist begleitet von einer umfangreichen Recherche und dem Experiment am Material. Eine intensive Auseinandersetzung mit Herstellungsmethoden und eine Entwicklungsbegleitung bis hin zur Serienreife ist ein wesentlicher Bestandteil der Arbeiten. Formstelle erarbeitet innovative Lösungen mit einem hohen Anspruch an konzeptionelle, technische und gestalterische Qualitäten.

EN Claudia Kleine (born 1974 in Munich) and Jörg Kürschner (born 1969 in Karlsruhe, carpenter and furniture restorer) both graduated from the Academy of Fine Arts in Munich with degrees in interior design. In 2001, they founded the office Formstelle in Munich, which undertakes design tasks in the fields of product design, interior design and corporate identity. The overarching spatial and substantial contexts play an important role for the design duo. Product design goes hand in hand with comprehensive research and material experiments. Paying special attention to production methods and accompanying products through the entire design process are an essential element of the work. Formstelle develops innovative solutions with a high standard of conceptual, technological and design quality.



FORMSTELLE  
CLAUDIA KLEINE; JÖRG KÜRSCHNER

# LOUNGE CHAIR 808



**808**  
GESTELL FLACHSTAHL EDELSTAHLLOPTIK,  
POLSTERUNG/  
FRAME FLAT STEEL STAINLESS STEEL DESIGN,  
UPHOLSTERY



**808 H UND 808**  
STAHLROHRGESTELL, POLSTERUNG/  
TUBULAR STEEL FRAME, UPHOLSTERY



**808 H UND 808**  
GESTELL NUSSBAUM GEÖLT, POLSTERUNG/  
FRAME WALNUT OILED, UPHOLSTERY



# LOUNGE CHAIR 809

# TABLE 1808/1809



**809**  
GESTELL FLACHSTAHL EDELSTAHOPTIK  
POLSTERUNG/  
FRAME FLAT STEEL STAINLESS STEEL DESIGN,  
UPHOLSTERY



**1808 TISCH NIEDRIG**  
**1809 TISCH HOCH**  
GESTELLE FLACHSTAHL EDELSTAHOPTIK  
PLATTEN EICHE KLAR LACKIERT/  
FRAMES FLAT STEEL STAINLESS STEEL DESIGN,  
TABLETOPS OAK CLEAR LACQUERED











DE Für das drehbare Gestell des 808 stehen unterschiedliche Varianten zur Auswahl. Durch die im Inneren des Möbels versteckte Mechanik kann der Sessel stufenlos in verschiedene Sitz- und Rücken- neigungen vor- und zurückbewegt werden, bis hin zu einer zurückgelehnten Ruhehaltung.

In Zusammenarbeit mit der deutschen Stoffmanufaktur Rohi haben die Designer einen individuellen Stoff für den 808 entwickelt: „Soul“ ist in dreizehn Farbtönen verfügbar und zeichnet sich durch den Einsatz hochwertiger Schurwollgarne und durch eine mehr- dimensionale wabenartige Struktur aus, die dem Stoff Tiefe verleiht. Alle Stoffe der Thonet-Kollektion sind möglich.

EN The swivel frame of the lounge chair 808 is available in a number of different versions. The mechanism hidden inside the chair enables the variable adjustment of multiple seat and backrest inclinations through to a relaxing fully reclined position.

The designers have created a distinct fabric for the lounge chair 808 in collaboration with the German textile manufacture Rohi: “Soul” is available in thirteen colours and impresses with a high-quality new woollen yarn and a multidimensional honey- comb structure that lends depth to the fabric. All fabrics of the Thonet collection are available.

## MATERIALIEN/MATERIALS

ALLE MATERIALIEN AUF ANFRAGE/  
ALL MATERIALS UPON REQUEST

### FARBWELT/COLOUR WORLD ROHI SOUL 808/809 EXCLUSIVE

#### STOFFE/FABRICS



#### GESTELL/FRAME

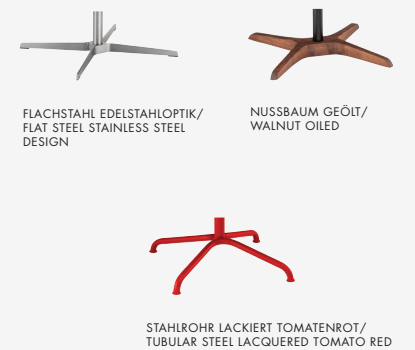

#### STAHLROHR/TUBURAR STEEL



#### MASSE/MEASUREMENTS

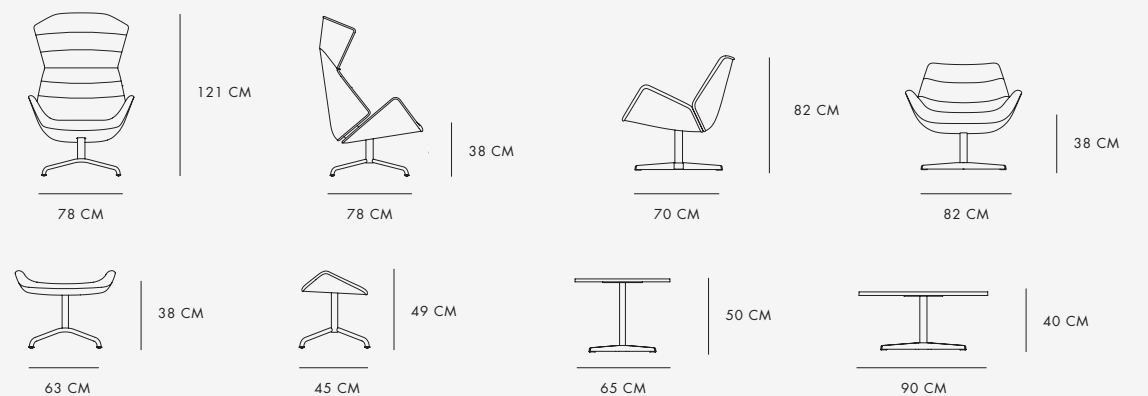



# THONET



#### CREDITS

**Photos:** Achim Hatzius, Christoph Gramann,  
Hartig & Thiel, Constantin Meyer

**Concept, layout:**

Lambl Office, Clara Huber

**Text:** Thonet GmbH,

Claudia Neumann Communication GmbH

**Translation:** SATS Translation Services

PB LOUNGE CHAIR 808/809

DE/EN

V2 2019

THONET GMBH  
MICHAEL-THONET-STRASSE 1  
35066 FRANKENBERG/EDER  
DEUTSCHLAND/GERMANY

T: +49 6451/508-0

F: +49 6451/508-108

E: MAILTO: INFO@THONET.DE

HTTP://WWW.THONET.DE



# STOFFEN

Thonet beschikt over een ruime collectie bijzondere stoffen voor zowel de woning- als de projectinrichting. De kwalitatief hoogwaardige meubelstoffen worden ingekocht bij gerenommeerde producenten. Alle collecties zijn geschikt voor de projectinrichting en hebben een slijtvastheid van minimaal 25.000 toeren (Martindale-test).

**De stoffen zijn verkrijgbaar in veel verschillende kleuren; hier ziet u slechts een kleine selectie. De afgebeelde kleuren kunnen licht afwijken van de originele materialen en stoffen. Wijzigingen voorbehouden. Voor de technische eigenschappen van de materialen verwijzen wij u naar de website van de fabrikant.**

**De stofgroepen verschillen in materiaal en prijs en zijn als volgt onderverdeeld:**

**Ingezonden stof:** katoenprijs

**Stofgroep I** Rivet, Step, Step Melange

**Stofgroep II** Field 2, Main Line Flax, Remix 2, Revive 1, ThonetMed®, ThonetTec®

**Stofgroep III** Credo, Mood, Novum, Soul

**Stofgroep IV** Divina Melange 3, Hallingdal 65, Steelcut Trio 3

**Ledergroep II** Maharam





# STOFFEN

## RIVET (CAMIRA, STOF I)

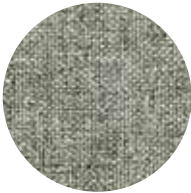

EGL01 Vitreous

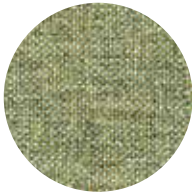

EGL11 Burnish

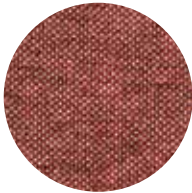

EGL12 Forge



EGL14 Copper

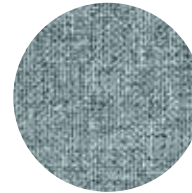

EGL16 Prime

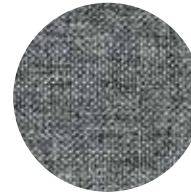

EGL18 Solder



EGL20 Tensile

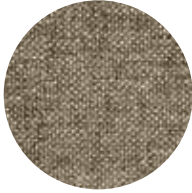

EGL25 Cast

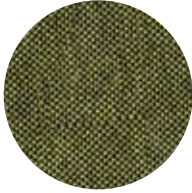

EGL31 Olive

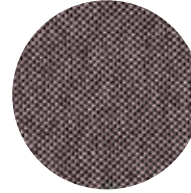

EGL33 Woodrose

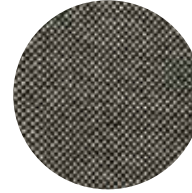

EGL49 Twig

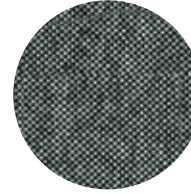

EGL50 Grey Brindle

## STEP (GABRIEL, STOF I)



63012



65047

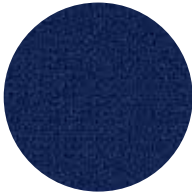

65018

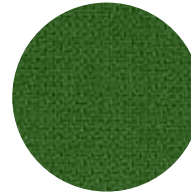

68120

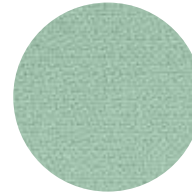

68118

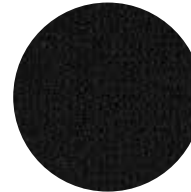

60999



60004



62057



68165

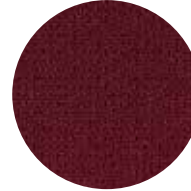

64159

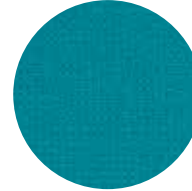

67073



62073

## STEP MELANGE (GABRIEL, STOF I)



61149



60004

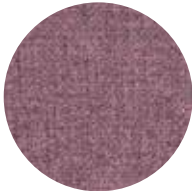

64181

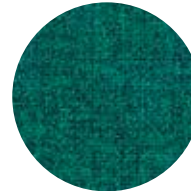

68157

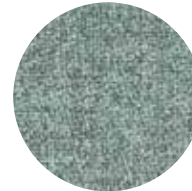

68118

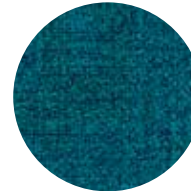

67007



63075



64179



62057

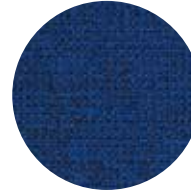

66150



68119

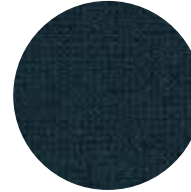

68158



# STOFFEN

## FIELD 2 (KVADRAT, STOF II)

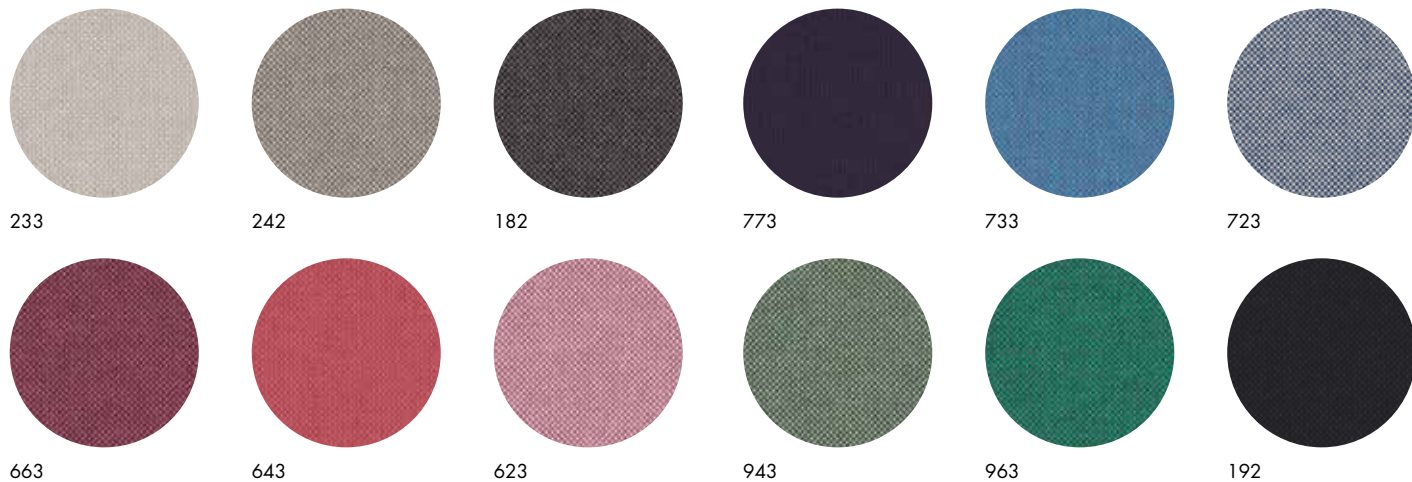

## MAIN LINE FLAX (CAMIRA, STOF II)



## REMIX 2 (KVADRAT, STOF II)

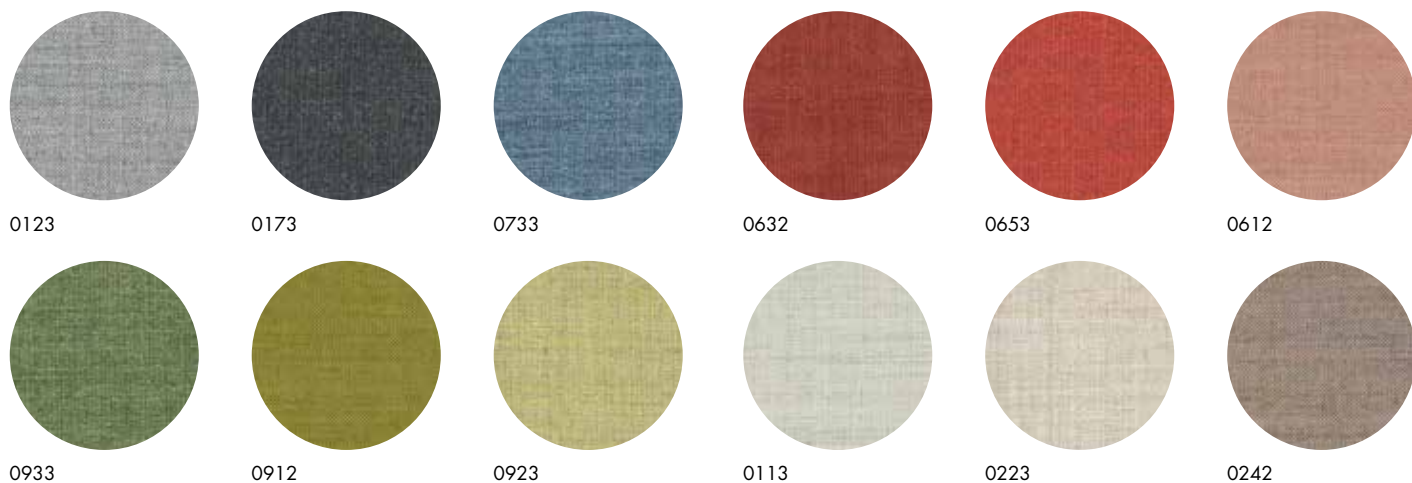



# STOFFEN

## REVIVE 1 (KVADRAT, STOF II)

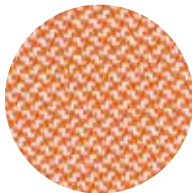

534 deep orange – white

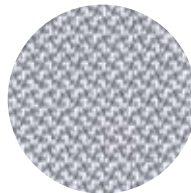

144 pastel blue – white

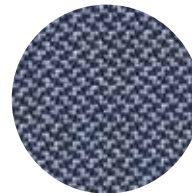

764 pastel blue – bluish black

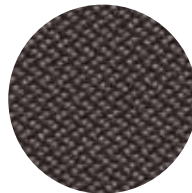

274 biscuit – taupe

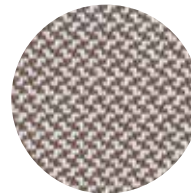

324 biscuit – white

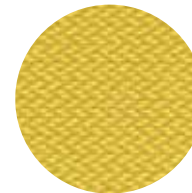

424 bright yellow – ochre yellow



224 white – light grey

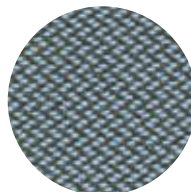

944 pastel blue – olive green



454 pastel yellow – graphite grey

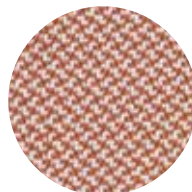

414 pastel yellow – pearl white



194 black

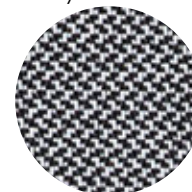

154 black – pearl white

## CREDO (ROHI, STOF III)

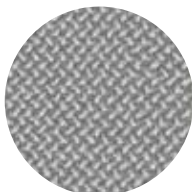

zinn

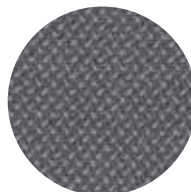

taupe

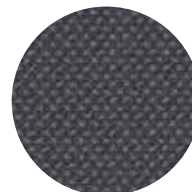

schiefer

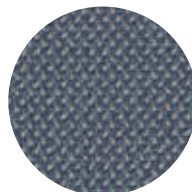

sea

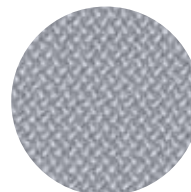

diamond

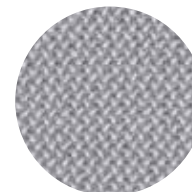

chalk



aureo

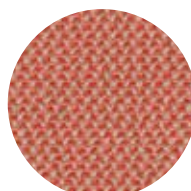

grapefruit

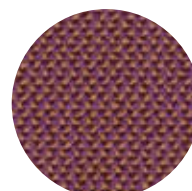

breva

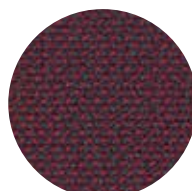

rubin

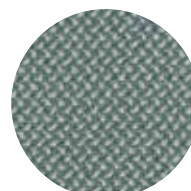

lake

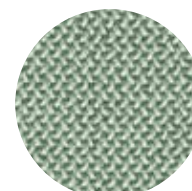

aloe

## MOOD (GABRIEL, STOF III)



5105



4103

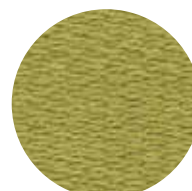

3104

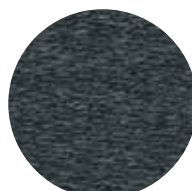

2107



4105



2105



8101

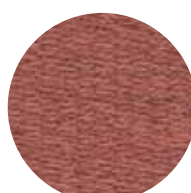

3105

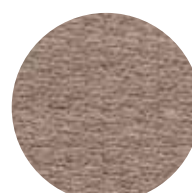

1103



2102

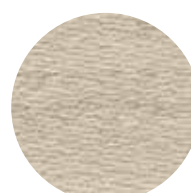

1104

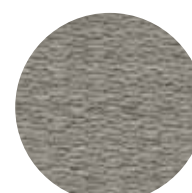

3101



# STOFFEN

## NOVUM (ROHI, STOF III)

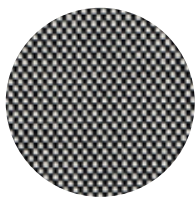

01 Pepper

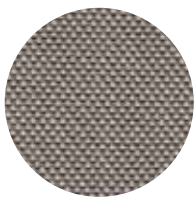

07 Stone

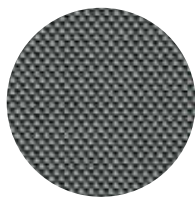

08 Prime

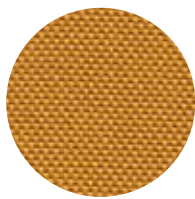

15 Curry

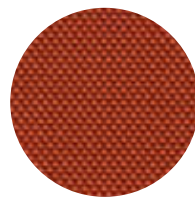

18 Coral

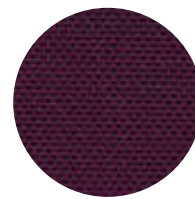

23 Viola

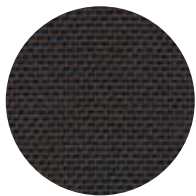

26 Lord

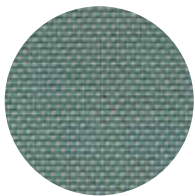

30 Lagoon

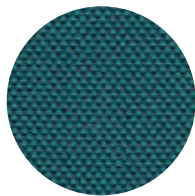

31 Prisma

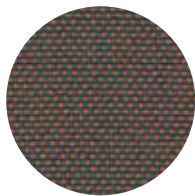

33 Mambo

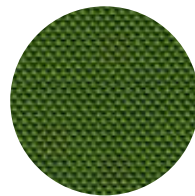

38 Moss



40 Pear

## SOUL (ROHI, STOF III)



angora



anthrazit



black

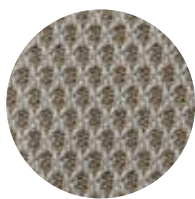

cocos



graphit

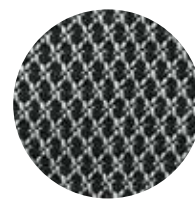

pepper

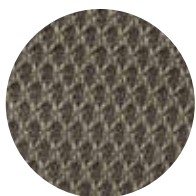

stone

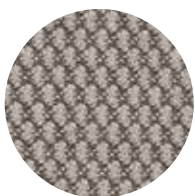

island

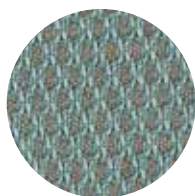

under

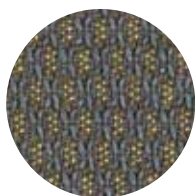

urban

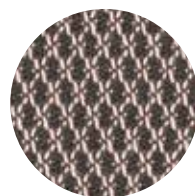

air

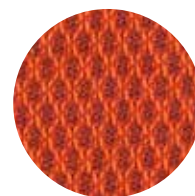

tropic

## DIVINA MELANGE 2 (KVADRAT, STOF IV)

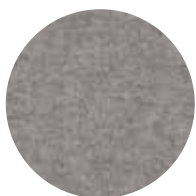

0120



0147



0277



0180



0967

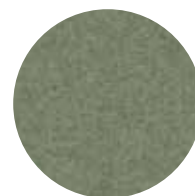

0917



0427



0547



0557



0620

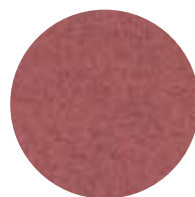

0617



0227



# STOFFEN

## HALLINGDAL 65 (KVADRAT, STOF IV)



457 Yellow

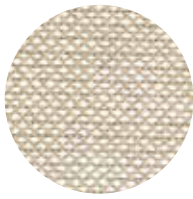

200 Beige

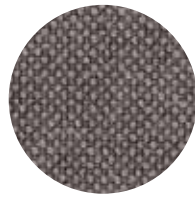

153 Grey

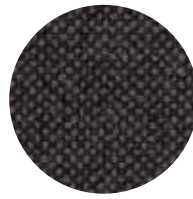

173 Black grey

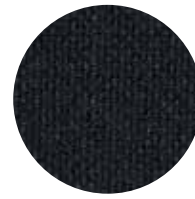

190 Black



370 Brown

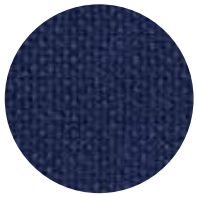

764 Dark blue

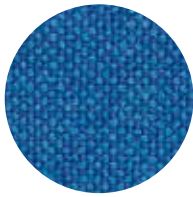

733 Blue



960 Green

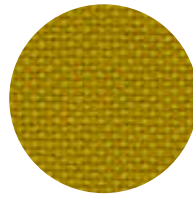

420 Yellow orange

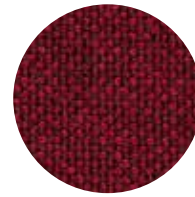

687 Bordeaux

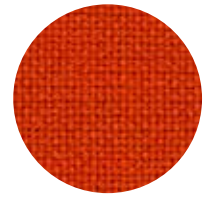

600 Orange

## STEELCUT TRIO 3 (KVADRAT, STOF IV)



0113

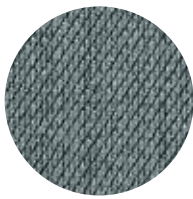

0153

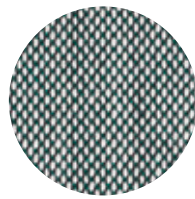

0916

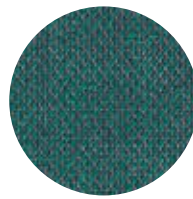

0996

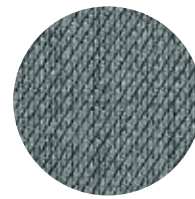

0153

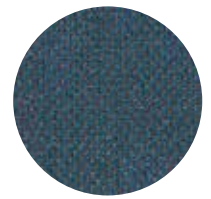

0756

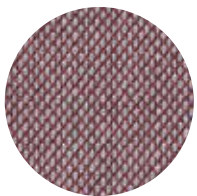

0276



0645



0453

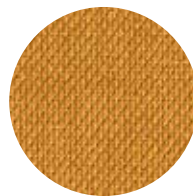

0466



0476

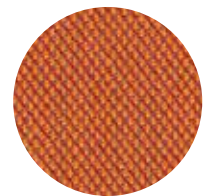

0576

## MAHARAM (KVADRAT, LEDER II)



Double Triangles

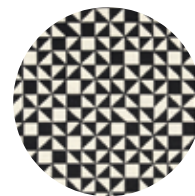

Checker Split



Facets



# THONET MED

Het kunstleder ThonetMef® skai® Parotega NF is door zijn natuurlijke uitstraling en oppervlak nauwelijks van echt leder te onderscheiden. Het is verkrijgbaar in 40 kleurnuances. Dit hoogwaardige, bijzonder onderhoudsvriendelijke en sterke kunstleder voldoet aan bouwmaterialenklasse B1 en heeft de hoogste brandwerende eigenschappen. Hierdoor is het ideaal voor de inrichting van publieke ruimten, verzorgingstehuizen, seniorenresidenties en ziekenhuizen, sportstudio's en fysiotherapiepraktijken. skai® Parotega NF is bestand tegen desinfecterende middelen, bloed en urine.

Materiaal: 85% polyvinyl, ondergrond 15% katoen  
Slijtvastheid: 75.000 Martindale

Brandwerende eigenschappen: DIN 4102-1 (Part 1, B1);  
DIN EN13507-1B; s3,d0; DIN 66084 P-α; NF M1, AM 18;  
BS5852 IS-0+1+5; DIN EN1021-1+2; DIN 4102-1(B2);  
FMVSS 302, FAR25.853; ÖNORM B3825 moeilijk ontvlambaar (B1);  
ÖNORM3800-1 Q1; UNI 9175/87 (1.IM)

**De afgebeelde kleuren kunnen licht afwijken van de originele materialen en stoffen. Wijzigingen voorbehouden.**

## THONET MED (STOF II)



F6461666



F6461654

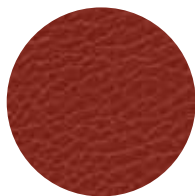

F6461702



F6461706

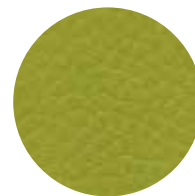

F6461657



F6461705

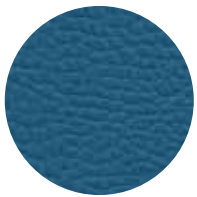

F6461709

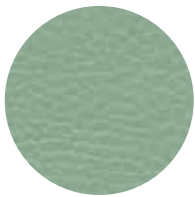

F6461767



F6461768

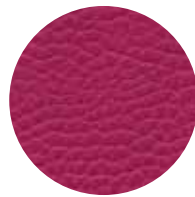

F6461735

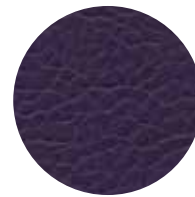

F6461736



F6461664





Het pvc-vrije kunstleder ThonetTec® skai® Pureto EN heeft een bijzonder zacht, warm oppervlak dat aan kalfsleder doet denken. Het is verkrijgbaar in 12 decante kleuren. Vanwege zijn uitstekende technische eigenschappen en onderhoudsvriendelijke karakter is het bijzonder geschikt voor moderne kantoor-, hotel- en horeca-richtingen. Het veganistische imitatieleer wordt gemaakt van sterk polyurethaan op waterbasis. Het is oplosmiddelvrij, waardoor het een goed milieuvriendelijk alternatief is.

Materiaal: coating 60% polyurethaan, ondergrond 40% katoen/polyester  
Slijtvastheid: 100.000 Martindale  
Brandwerende eigenschappen: EN 1021-1-2; FMVSS 302

**De afgebeelde kleuren kunnen licht afwijken van de originele materialen en stoffen. Wijzigingen voorbehouden.**

## THONET TEC (STOF II)

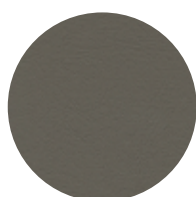

F7610008



F7610009



F7610010

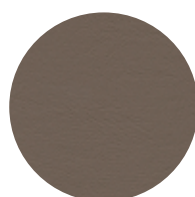

F7610011

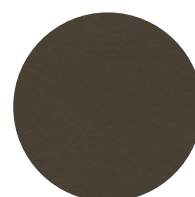

F7610012

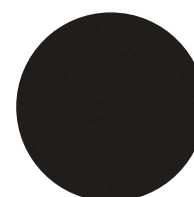

F7610020



F7610014

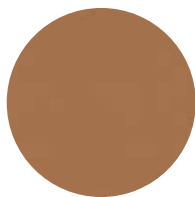

F7610015



F7610016

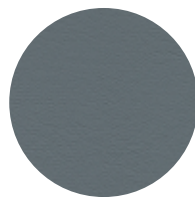

F7610017

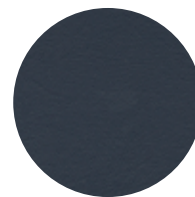

F7610018

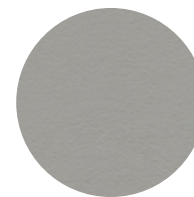

F7610019





# STOFCLASSIFICATIE

KVADRAT	THONET STOFGROEP
Atlas	stof IV
Basel	stof IV
Canvas 2	leder IV
Checker Split	leder II
Clara 2	stof IV
Coda 2	leder I / stof V
Divina 3	stof IV
Divina MD	leder I / stof V
Divina Melange 2	stof IV
Double Triangles	leder II
Facets	leder II
Field 2	stof II
Fiord 2	leder I / stof V
Hallingdal 65	stof IV
Harald 3	leder I / stof V
Letters	leder II
Lila	leder I / stof V
Melange Nap	stof IV
Molly 2	leder I / stof V
Patio	stof IV
Pro 3	stof IV
Raas	leder I / stof V
Remix 2	stof II
Revive 1	stof II
Re-wool	stof IV
Rime	leder I / stof V
Savanna	stof IV
Star 2	leder I / stof V
Steelcut 2	stof IV
Steelcut Trio 3	stof IV
Still	stof IV
Sunniva 2	leder I / stof V
Tonus 4	leder I / stof V

CAMIRA	THONET STOFGROEP
24 / 7 +	stof IV
Acrobat ( Net)	leder I / stof V
Advantage	stof II
Aquarius	stof III
Aspect	stof III
Blazer	stof IV
Blazer Quilt Channel	leder I / stof V
Blazer Quilt Hourglass	leder I / stof V
Canopy	stof II
Century	leder I / stof V
Chateau	stof II
Citadel	stof I
Corrosion	leder I / stof V
Craggan	leder I / stof V
Craggan Flax	leder I / stof V
Era	stof I
Figaro	stof II
Gravity	stof II
Hemp	stof IV
Hi-Tech	stof IV
Individuo	leder I / stof V
Landscape - Collection Synergy	stof IV
Main Line Flax	stof II
Main Line Flax Stripe	leder I / stof V
Main Line Plus	stof III
Manhattan	stof II
Oxygen	stof IV
Patina	stof III
Phoenix	stof II
Rivet	stof I
Silk	stof IV
Sprint	stof II
Stripes	leder I / stof V
Synergy	stof IV
Synergy Quilt Channel	leder I / stof V
Synergy Quilt Chevron	leder I / stof V
Synergy Quilt Hourglass	leder I / stof V
Touch FR	stof IV
Track	stof IV
Urban	stof II
Vintage ( leder )	leder I / stof V
Vita	stof II
X2	stof III
Xtreme	stof I
Xtreme CS	stof III



# STOFCLASSIFICATIE

GABRIEL	THONET STOFGROEP
Atlantic	stof II
Bond	stof II
Breeze Fusion	stof III
Capture	stof III
Chili	stof III
Comfort+	leder I / stof V
Crisp	stof IV
Criss Cross	stof IV
Cura	stof II
Europost2	stof III
Event	stof I
Fame	stof III
Fame Hybrid	stof III
Felicity	stof II
Fighter	stof I
Flex	stof II
Gaja Antistatic	stof IV
Gaja C2C	stof IV
Gaja Classic	stof III
Go Check	stof I
Go Uni	stof I
Go Couture	stof I
Harlequin	stof III
Harmony	stof III
Just	stof II
Luna 2	stof IV
Luna Fleur 2	leder I / stof V
Medley	stof II
Mica	stof II
Mood	stof III
Morph	stof IV
Noma	stof III
Obika Leather+	stof IV
Omega	stof III
Passion	stof IV
Repetto	stof II
Rhythm	stof III
Rondo	stof II
Runner	stof III
Step	stof I
Step Melange	stof I
Savak	leder I / stof V

GABRIEL	THONET STOFGROEP
Savoy	leder I / stof V
Select	stof III
Spin	stof III
String	stof I
Swing	stof III
Tempt	stof III
Tonal	stof II
Vivid	stof II
Web	stof III

ROHI	THONET STOFGROEP
Arco	stof IV
Credo	stof III
Dante	stof IV
Mica	stof IV
Novum	stof III
Opera	stof IV
Sera	stof IV
Shake	stof III
Soul	stof III
Topia	stof III



# LEDER

## LEDER

Thonet gebruikt uitsluitend hoogwaardig Europees rundleder. Aan het looien en verven worden strenge milieueisen gesteld. De huid wordt voor de verwerking gecontroleerd. Net als bij alle natuurproducten kan het leder lichte onregelmatigheden en verschillen vertonen. Thonet verwerkt nappaleder met een semi-aniline finish. Onafhankelijk van de manier van verwerking kunnen plooiën ontstaan, omdat leder van nature rekbaar is. Informatie over de verzorging van ons leder vindt u op <http://nl.thonet.de>.

## VOLFNERF KERNLEDER

Voor de ‚Freischwinger‘-modellen S 33, S 34, S 35 en S 533 wordt hoogwaardig kernleder gebruikt. Dit heeft een dikte van 3,0 tot 3,3 mm en wordt aan de onderzijde met stof versterkt.

## KOEIENHUID

De koeienhuiden zijn afkomstig van Europese runderen. Kenmerkend voor het natuurlijke karakter van dit hoogwaardige materiaal zijn de verschillende vlekken en haarlengte. Om vervilt en kaal worden tegen te gaan, moet koeienhuid ongeveer eens in de drie maanden worden gekamd met een gewone roskam of een zachte hondenborstel.

**De afgebeelde kleuren kunnen licht afwijken van de originele materialen en stoffen. Wijzigingen voorbehouden.**

## LEDER

(De 12 hier afgebeelde kleuren maken deel uit van de Thonet Linea collectie en behoren tot groep Leder I, andere kleuren uit deze Linea collectie behoren tot groep Leder II).



635 Latte



659 Tortora



612 Castagna



680 New Cognac



681 Muscat

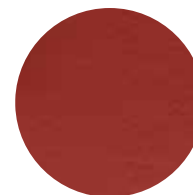

613 Mattone



657 Rosso Antico



631 Green



640 Mascara

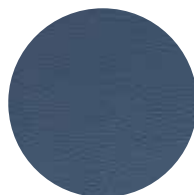

703 Ming



670 Highway



622 Nero



# LEDER

## NUBUKLEDER (LEDER III)

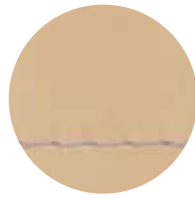

4 Sandbeige  
Seam colour:  
634 Warm grey

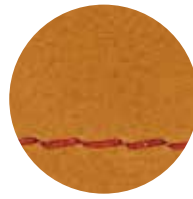

5 Ochre-brown  
Seam colour:  
221 Red

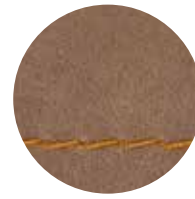

1 Medium brown  
Seam colour:  
448 Orange brown



8 Greengrey  
Seam colour:  
32 Black blue

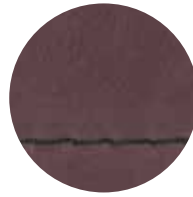

2 Purple  
Seam colour:  
707 Green



9 Dark brown  
Seam colour:  
887 Ochre-brown

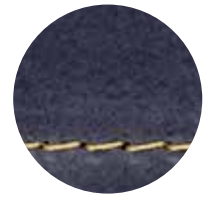

10 Black  
Seam colour:  
968 Yellow

## NAPPALEDER (LEDER III)

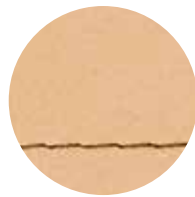

3446 Sand  
Seam colour:  
406 Dark brown

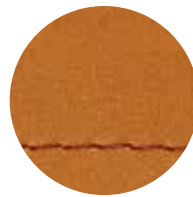

2617 Cognac  
Seam colour:  
406 Dark brown

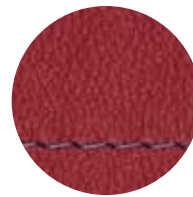

4223 Bordeaux  
Seam colour:  
302 Pine green

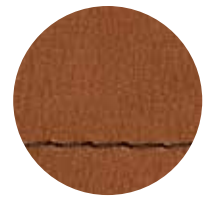

2488 Medium brown  
Seam colour: 000 Black

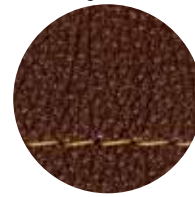

2001 Dark brown  
Seam colour:  
887 Ochre-brown

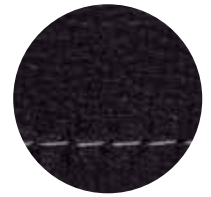

500 Black  
Seam colour:  
701 Grey

## VOLFNERF KERNLEDER



Granite

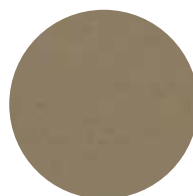

Mud grey

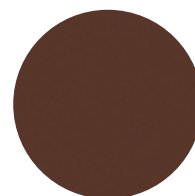

Chocolate



Black