

FIRE LINE AUTOMATIC 3+ (790mm) AUTOMATIC ETHANOL BURNER

BEV Technology®

FLAME CONTROL

Have control over the fire and take advantage of the 6-stage flame height regulation.

GLASS SCREEN

The dedicated toughened glass panel covers and stabilizes the flame.

AUTOMATIC BURNER

The automatic burner with the patented BEV Technology® is the most advanced product in the industry ensuring the cleanest burning process without any smoke, smell or ash. The flame is produced by combusting ethanol vapours and has no direct contact with the liquid fuel.

AUTOMATIC REFILLING SYSTEM

The automatic pump communicates with the device, delivering the necessary amount of fuel. There is no risk of overfilling the tank or spilling the fuel.

INTEGRATED CONTROL PANEL

The FLA3+ burner has an intuitive control panel with an LCD screen and inlet for automatic refuelling.

BEST BUILD QUALITY

The product passed extensive tests carried out by the leading certification institutes. It is manufactured according to UL standards and is O-TL certified, meeting the most demanding safety and quality requirements.

REMOTE CONTROL

Control the fire with the included remote, app on your smartphone or home automation system.



Fire Line Automatic 3+ (790mm)

(BEV Technology®)

Fuel tank capacity	13.4 L
Maximum burn time	32 hours
Maximum heat output	4.4 kW
Minimum room cubature	44 m ³
Flame height regulation	6 stages
Weight	29.0 kg
Fuel type	bioethanol 86 - 96,6%
Flue	not required
Air change rate	1 space volume per hour
Power supply	230 V
Finish	black powder coating
Materials	steel, galvanized steel, toughened glass
Application	for indoor use only

CONTROL OPTIONS



included



included



optional

'PLANIKA N-CONTROL' APP

Control the fire with your smartphone!

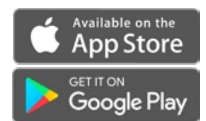

O-TL certified 

Manufactured to UL standards

custom length
available on request



glass screens for See-Through and Room
Divider housings are available separately

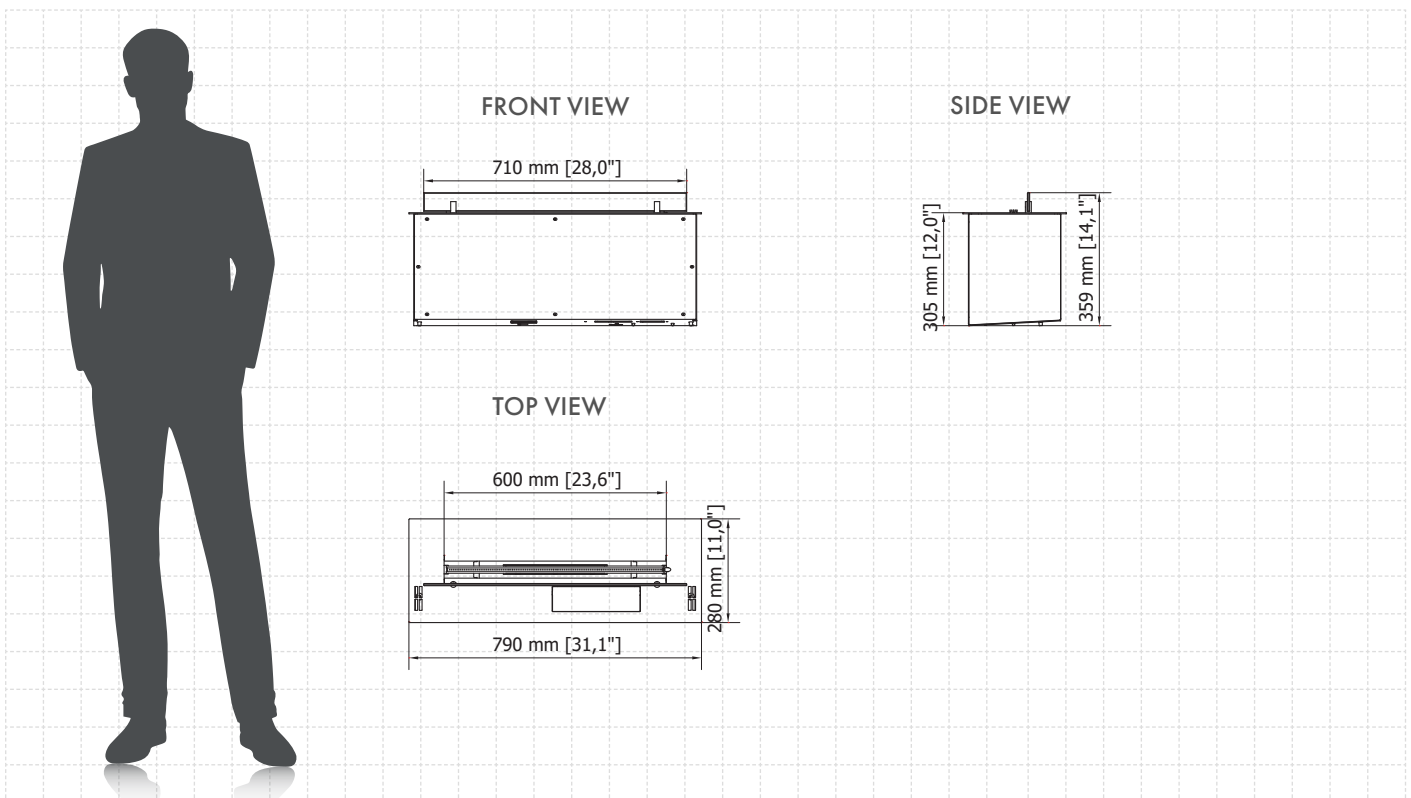
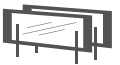

All product specifications and data are subject to change without notice and are believed to be accurate as of the date hereof. Planika Sp. z o.o., its affiliates, agents, and employees, and all persons acting on its or their behalf (collectively, "Planika Sp. z o.o."), disclaim any and all liability for any errors, inaccuracies or incompleteness contained in any document or in any other disclosure relating to any product. To the maximum extent permitted by applicable law, Planika Sp. z o.o. disclaims any and all liability arising out of the application or use of any product. This document does not expand or otherwise modify Planika Sp. z o.o.'s terms and conditions of purchase, including but not limited to the warranty expressed therein. No license, express or implied, by estoppel or otherwise, to any intellectual property rights is granted by this document or by any conduct of Planika Sp. z o.o.. Customers using or selling Planika Sp. z o.o.'s products not expressly indicated for use in such applications do so entirely at their own risk and agree to fully indemnify Planika Sp. z o.o. for any damages arising or resulting from such use or sale. The images are indicative only.

FIRE LINE AUTOMATIC 3+ (990mm) AUTOMATIC ETHANOL BURNER

BEV Technology®

AUTOMATIC BURNER

The automatic burner with the patented BEV Technology® is the most advanced product in the industry ensuring the cleanest burning process without any smoke, smell or ash. The flame is produced by combusting ethanol vapours and has no direct contact with the liquid fuel.

FLAME CONTROL
Have control over the fire and take advantage of the 6-stage flame height regulation.

GLASS SCREEN
The dedicated toughened glass panel covers and stabilizes the flame.

AUTOMATIC REFILLING SYSTEM

The automatic pump communicates with the device, delivering the necessary amount of fuel. There is no risk of overfilling the tank or spilling the fuel.

BEST BUILD QUALITY

The product passed extensive tests carried out by the leading certification institutes. It is manufactured according to UL standards and is O-TL certified, meeting the most demanding safety and quality requirements.

INTEGRATED CONTROL PANEL

The FLA3+ burner has an intuitive control panel with an LCD screen and inlet for automatic refuelling.

REMOTE CONTROL

Control the fire with the included remote, app on your smartphone or home automation system.



Fire Line Automatic 3+ (990mm)

(BEV Technology®)

Fuel tank capacity	17.2 L
Maximum burn time	32 hours
Maximum heat output	7.0 kW
Minimum room cubature	70 m ³
Flame height regulation	6 stages
Weight	36.0 kg
Fuel type	bioethanol 86 - 96,6%
Flue	not required
Air change rate	1 space volume per hour
Power supply	230 V
Finish	black powder coating
Materials	steel, galvanized steel, toughened glass
Application	for indoor use only

CONTROL OPTIONS



included



included



optional

'PLANIKA N-CONTROL' APP

Control the fire with your smartphone!



O-TL certified 

Manufactured to UL standards

custom length
available on request



glass screens for See-Through and Room
Divider housings are available separately

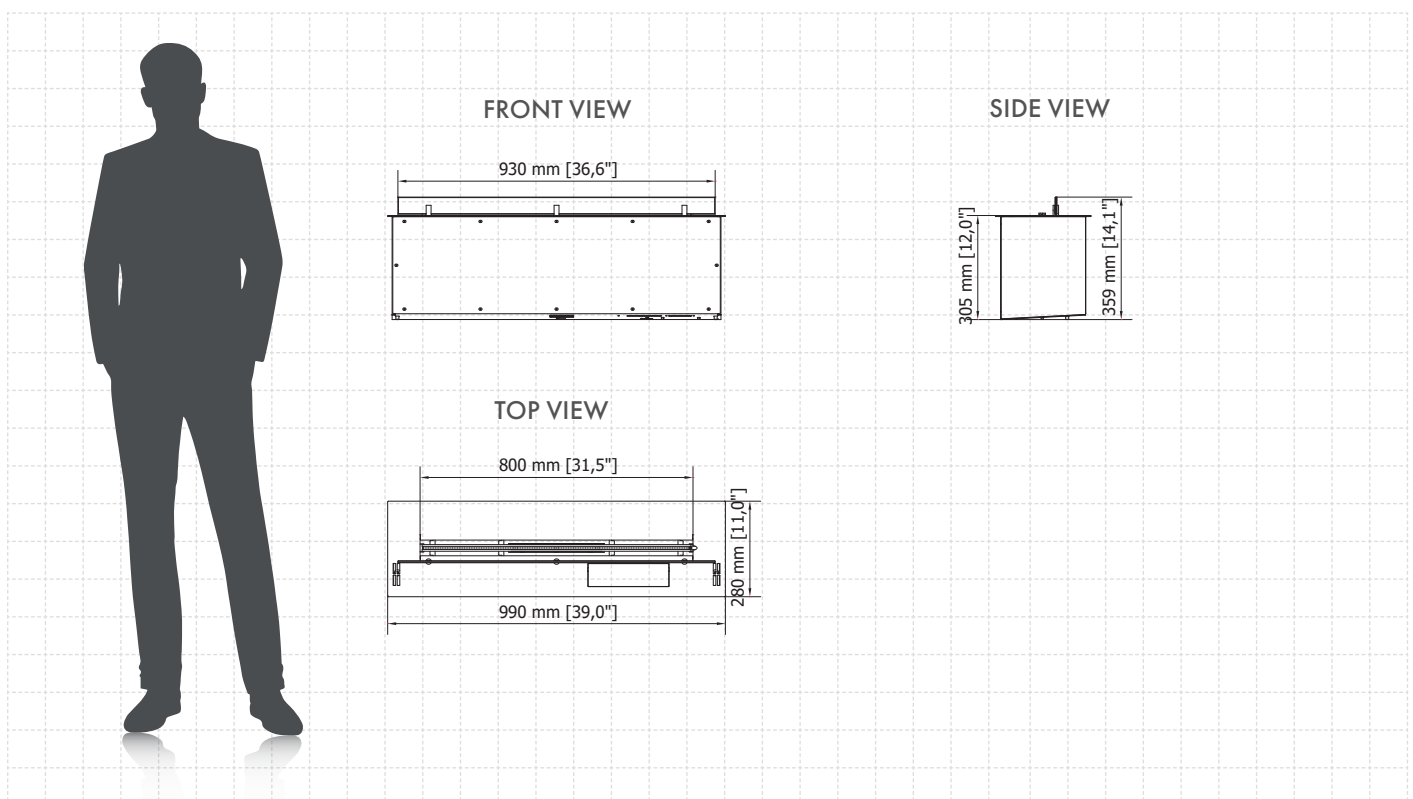

All product specifications and data are subject to change without notice and are believed to be accurate as of the date hereof. Planika Sp. z o.o., its affiliates, agents, and employees, and all persons acting on its or their behalf (collectively, "Planika Sp. z o.o."), disclaim any and all liability for any errors, inaccuracies or incompleteness contained in any document or in any other disclosure relating to any product. To the maximum extent permitted by applicable law, Planika Sp. z o.o. disclaims any and all liability arising out of the application or use of any product. This document does not expand or otherwise modify Planika Sp. z o.o.'s terms and conditions of purchase, including but not limited to the warranty expressed therein. No license, express or implied, by estoppel or otherwise, to any intellectual property rights is granted by this document or by any conduct of Planika Sp. z o.o.. Customers using or selling Planika Sp. z o.o.'s products not expressly indicated for use in such applications do so entirely at their own risk and agree to fully indemnify Planika Sp. z o.o. for any damages arising or resulting from such use or sale. The images are indicative only.

FIRE LINE AUTOMATIC 3+ (1190mm) AUTOMATIC ETHANOL BURNER

BEV Technology®

FLAME CONTROL

Have control over the fire and take advantage of the 6-stage flame height regulation.

GLASS SCREEN

The dedicated toughened glass panel covers and stabilizes the flame.

AUTOMATIC REFILLING SYSTEM

The automatic pump communicates with the device, delivering the necessary amount of fuel. There is no risk of overfilling the tank or spilling the fuel.

INTEGRATED CONTROL PANEL

The FLA3+ burner has an intuitive control panel with an LCD screen and inlet for automatic refuelling.

AUTOMATIC BURNER

The automatic burner with the patented BEV Technology® is the most advanced product in the industry ensuring the cleanest burning process without any smoke, smell or ash. The flame is produced by combusting ethanol vapours and has no direct contact with the liquid fuel.

BEST BUILD QUALITY

The product passed extensive tests carried out by the leading certification institutes. It is manufactured according to UL standards and is O-TL certified, meeting the most demanding safety and quality requirements.

REMOTE CONTROL

Control the fire with the included remote, app on your smartphone or home automation system.

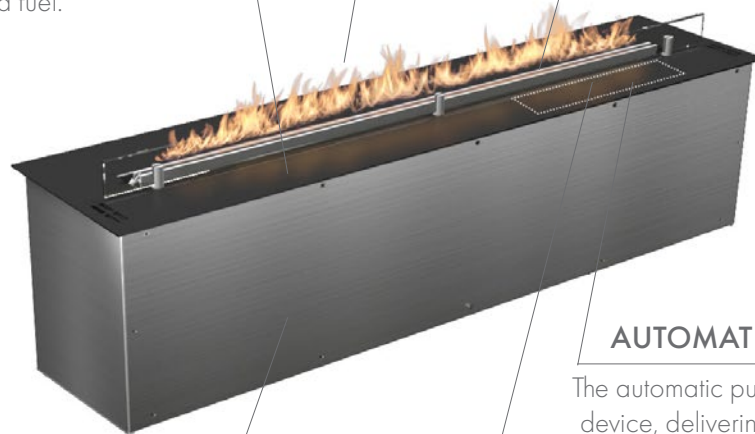

Fire Line Automatic 3+ (1190mm)

(BEV Technology®)

Fuel tank capacity	21.0 L
Maximum burn time	32 hours
Maximum heat output	9.4 kW
Minimum room cubature	94 m ³
Flame height regulation	6 stages
Weight	43.2 kg
Fuel type	bioethanol 86 - 96,6%
Flue	not required
Air change rate	1 space volume per hour
Power supply	230 V
Finish	black powder coating
Materials	steel, galvanized steel, toughened glass
Application	for indoor use only

CONTROL OPTIONS



included



included



optional

'PLANIKA N-CONTROL' APP

Control the fire with your smartphone!



O-TL certified 

Manufactured to UL standards

custom length
available on request



glass screens for See-Through and Room
Divider housings are available separately

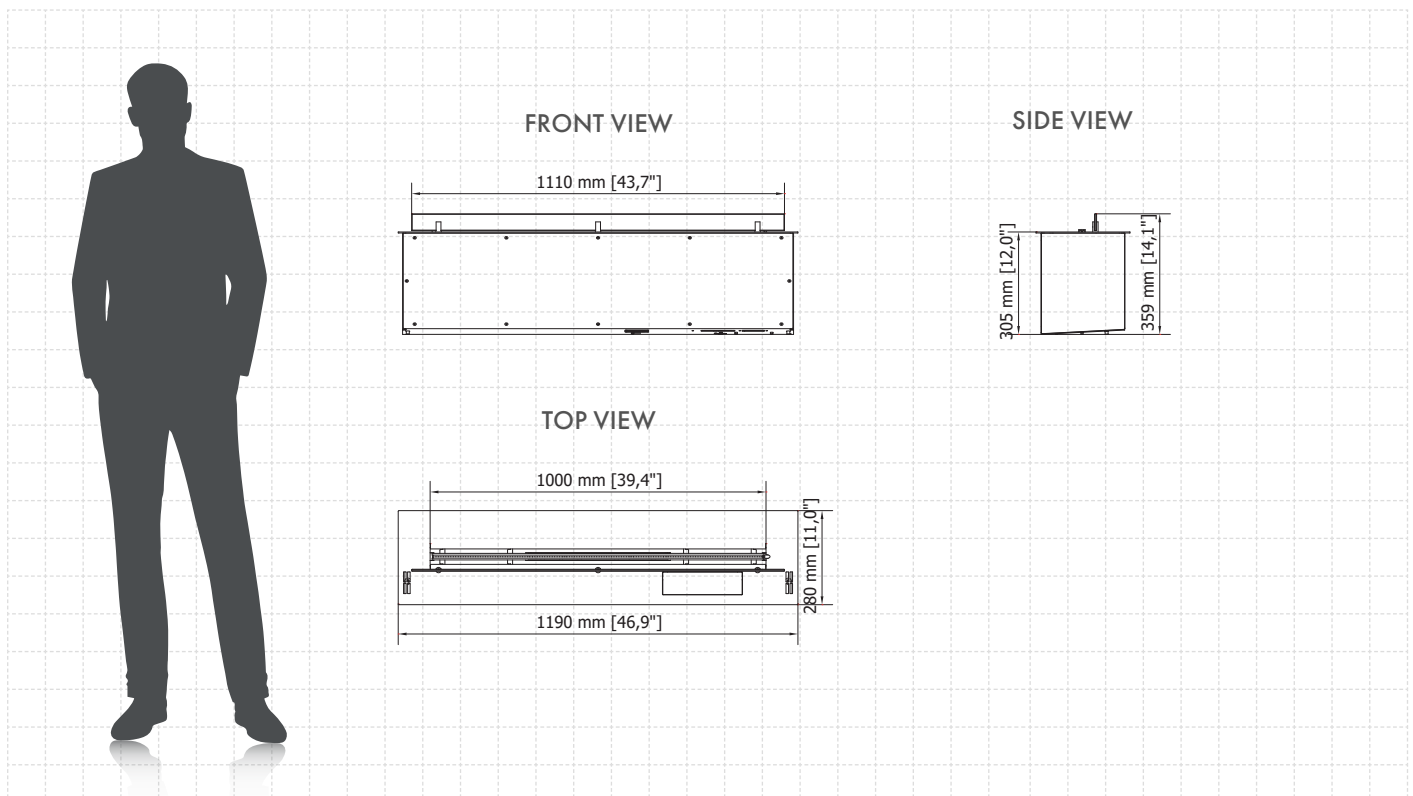

All product specifications and data are subject to change without notice and are believed to be accurate as of the date hereof. Planika Sp. z o.o., its affiliates, agents, and employees, and all persons acting on its or their behalf (collectively, "Planika Sp. z o.o."), disclaim any and all liability for any errors, inaccuracies or incompleteness contained in any document or in any other disclosure relating to any product. To the maximum extent permitted by applicable law, Planika Sp. z o.o. disclaims any and all liability arising out of the application or use of any product. This document does not expand or otherwise modify Planika Sp. z o.o.'s terms and conditions of purchase, including but not limited to the warranty expressed therein. No license, express or implied, by estoppel or otherwise, to any intellectual property rights is granted by this document or by any conduct of Planika Sp. z o.o.. Customers using or selling Planika Sp. z o.o.'s products not expressly indicated for use in such applications do so entirely at their own risk and agree to fully indemnify Planika Sp. z o.o. for any damages arising or resulting from such use or sale. The images are indicative only.

FIRE LINE AUTOMATIC 3+ (1490mm) AUTOMATIC ETHANOL BURNER

BEV Technology[®]

FLAME CONTROL

Have control over the fire and take advantage of the 6-stage flame height regulation.

GLASS SCREEN

The dedicated toughened glass panel covers and stabilizes the flame.

AUTOMATIC REFILLING SYSTEM

The automatic pump communicates with the device, delivering the necessary amount of fuel. There is no risk of overfilling the tank or spilling the fuel.

INTEGRATED CONTROL PANEL

The FLA3+ burner has an intuitive control panel with an LCD screen and inlet for automatic refuelling.

AUTOMATIC BURNER

The automatic burner with the patented BEV Technology[®] is the most advanced product in the industry ensuring the cleanest burning process without any smoke, smell or ash. The flame is produced by combusting ethanol vapours and has no direct contact with the liquid fuel.

BEST BUILD QUALITY

The product passed extensive tests carried out by the leading certification institutes. It is manufactured according to UL standards and is O-TL certified, meeting the most demanding safety and quality requirements.

REMOTE CONTROL

Control the fire with the included remote, app on your smartphone or home automation system.

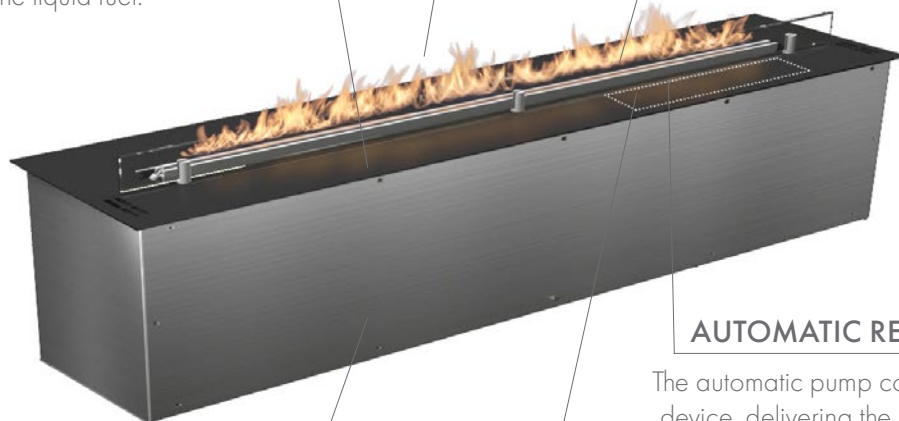

Fire Line Automatic 3+ (1490mm)

(BEV Technology®)

Fuel tank capacity	26.8 L
Maximum burn time	32 hours
Maximum heat output	13.0 kW
Minimum room cubature	130 m ³
Flame height regulation	6 stages
Weight	51.6 kg
Fuel type	bioethanol 86 - 96,6%
Flue	not required
Air change rate	1 space volume per hour
Power supply	230 V
Finish	black powder coating
Materials	steel, galvanized steel, toughened glass
Application	for indoor use only

CONTROL OPTIONS



included



included



optional

'PLANIKA N-CONTROL' APP

Control the fire with your smartphone!



O-TL certified 

Manufactured to UL standards

custom length
available on request



glass screens for See-Through and Room
Divider housings are available separately

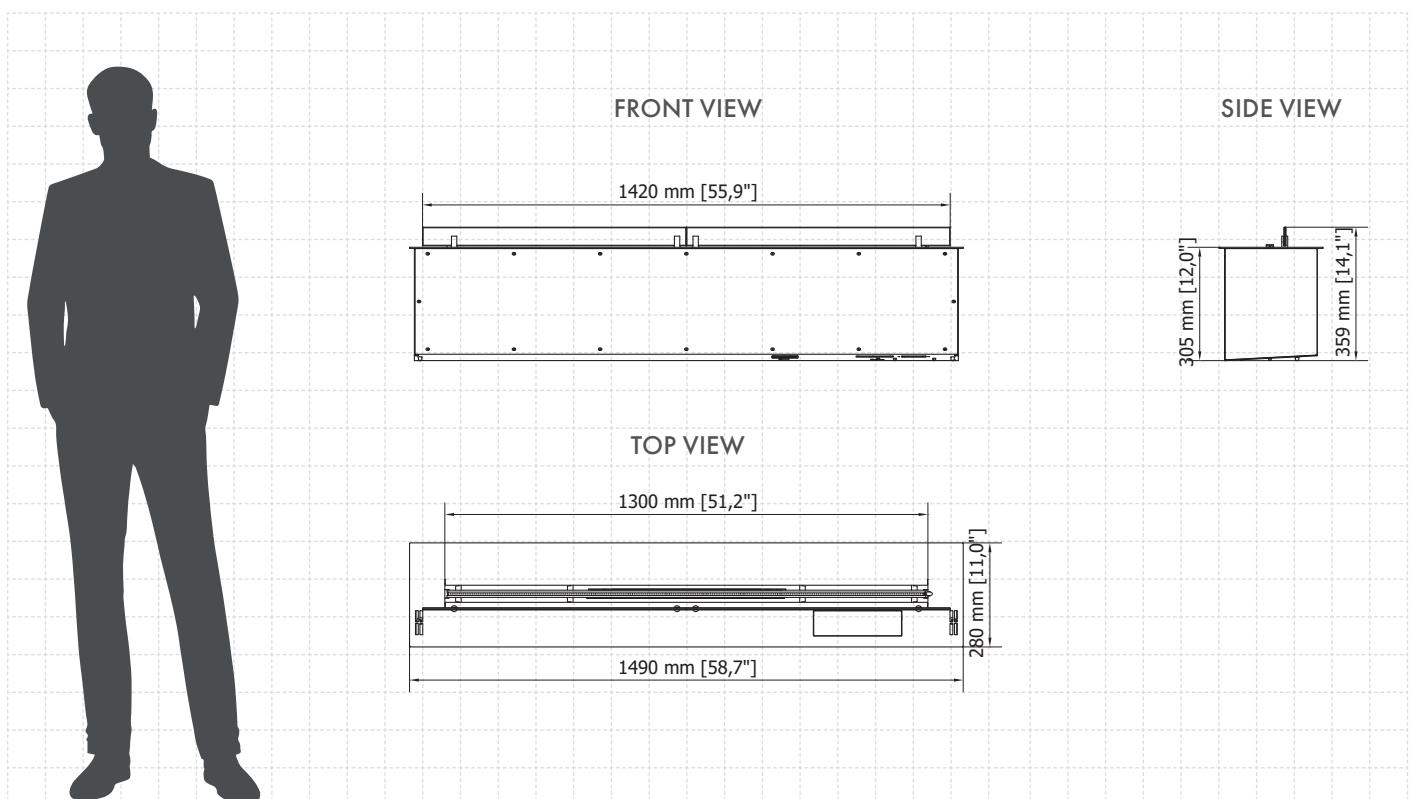
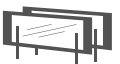

All product specifications and data are subject to change without notice and are believed to be accurate as of the date hereof. Planika Sp. z o.o., its affiliates, agents, and employees, and all persons acting on its or their behalf (collectively, "Planika Sp. z o.o."), disclaim any and all liability for any errors, inaccuracies or incompleteness contained in any document or in any other disclosure relating to any product. To the maximum extent permitted by applicable law, Planika Sp. z o.o. disclaims any and all liability arising out of the application or use of any product. This document does not expand or otherwise modify Planika Sp. z o.o.'s terms and conditions of purchase, including but not limited to the warranty expressed therein. No license, express or implied, by estoppel or otherwise, to any intellectual property rights is granted by this document or by any conduct of Planika Sp. z o.o.. Customers using or selling Planika Sp. z o.o.'s products not expressly indicated for use in such applications do so entirely at their own risk and agree to fully indemnify Planika Sp. z o.o. for any damages arising or resulting from such use or sale. The images are indicative only.

FIRE LINE AUTOMATIC 3+ (1990mm) AUTOMATIC ETHANOL BURNER

BEV Technology®

FLAME CONTROL

Have control over the fire and take advantage of the 6-stage flame height regulation.

GLASS SCREEN

The dedicated toughened glass panel covers and stabilizes the flame.

AUTOMATIC BURNER

The automatic burner with the patented BEV Technology® is the most advanced product in the industry ensuring the cleanest burning process without any smoke, smell or ash. The flame is produced by combusting ethanol vapours and has no direct contact with the liquid fuel.

AUTOMATIC REFILLING SYSTEM

The automatic pump communicates with the device, delivering the necessary amount of fuel. There is no risk of overfilling the tank or spilling the fuel.

INTEGRATED CONTROL PANEL

The FLA3+ burner has an intuitive control panel with an LCD screen and inlet for automatic refuelling.

BEST BUILD QUALITY

The product passed extensive tests carried out by the leading certification institutes. It is manufactured according to UL standards and is O-TL certified, meeting the most demanding safety and quality requirements.

REMOTE CONTROL

Control the fire with the included remote, app on your smartphone or home automation system.



Fire Line Automatic 3+ (1990mm)

(BEV Technology®)

Fuel tank capacity	36.3 L
Maximum burn time	32 hours
Maximum heat output	18.0 kW
Minimum room cubature	180 m ³
Flame height regulation	6 stages
Weight	72.0 kg
Fuel type	bioethanol 86 - 96,6%
Flue	not required
Air change rate	1 space volume per hour
Power supply	230 V
Finish	black powder coating
Materials	steel, galvanized steel, toughened glass
Application	for indoor use only

CONTROL OPTIONS



included



included



optional

'PLANIKA N-CONTROL' APP

Control the fire with your smartphone!



O-TL certified 

Manufactured to UL standards

custom length
available on request



glass screens for See-Through and Room
Divider housings are available separately

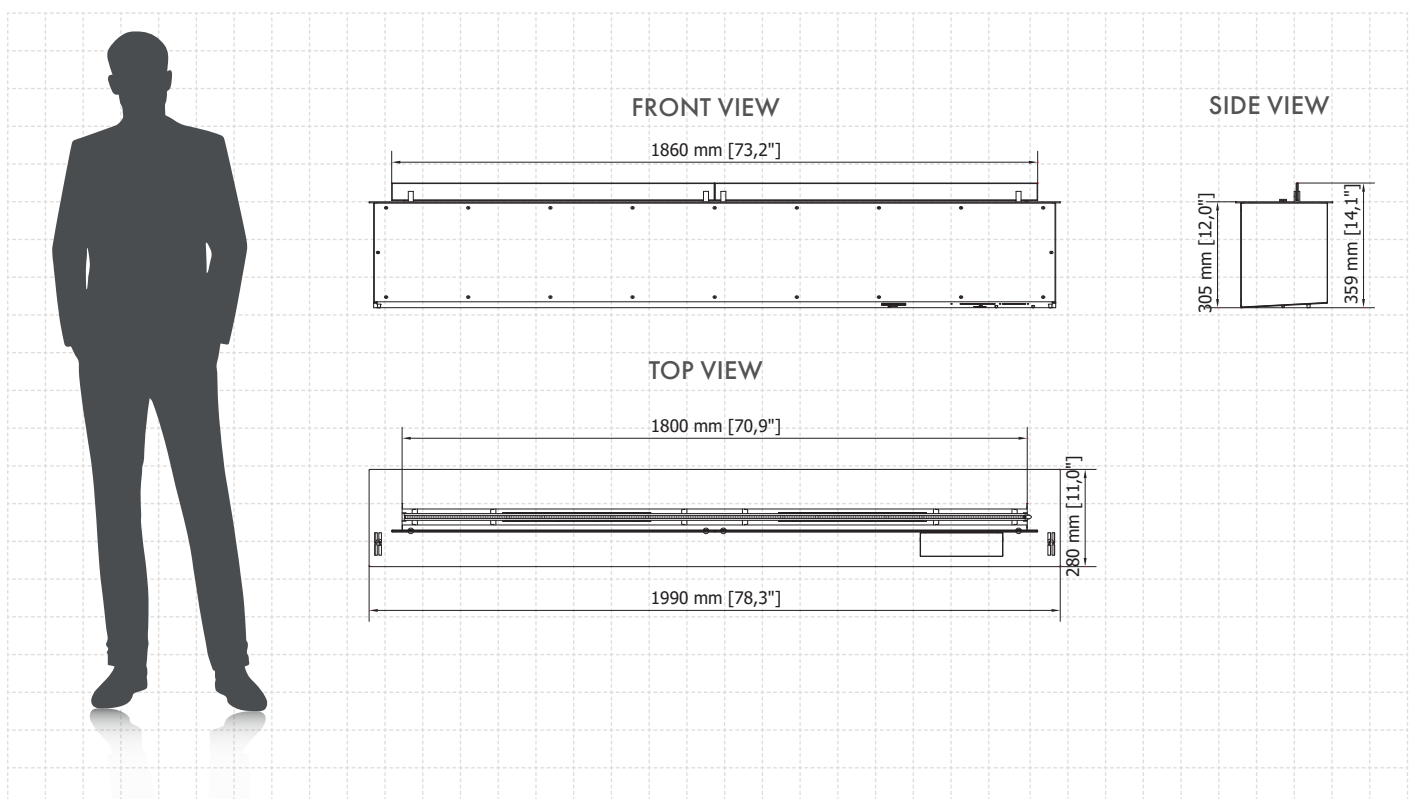
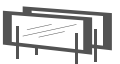

All product specifications and data are subject to change without notice and are believed to be accurate as of the date hereof. Planika Sp. z o.o., its affiliates, agents, and employees, and all persons acting on its or their behalf (collectively, "Planika Sp. z o.o."), disclaim any and all liability for any errors, inaccuracies or incompleteness contained in any document or in any other disclosure relating to any product. To the maximum extent permitted by applicable law, Planika Sp. z o.o. disclaims any and all liability arising out of the application or use of any product. This document does not expand or otherwise modify Planika Sp. z o.o.'s terms and conditions of purchase, including but not limited to the warranty expressed therein. No license, express or implied, by estoppel or otherwise, to any intellectual property rights is granted by this document or by any conduct of Planika Sp. z o.o.. Customers using or selling Planika Sp. z o.o.'s products not expressly indicated for use in such applications do so entirely at their own risk and agree to fully indemnify Planika Sp. z o.o. for any damages arising or resulting from such use or sale. The images are indicative only.

FIRE LINE AUTOMATIC 3+ (2490mm) AUTOMATIC ETHANOL BURNER

BEV Technology®

FLAME CONTROL

Have control over the fire and take advantage of the 6-stage flame height regulation.

AUTOMATIC BURNER

The automatic burner with the patented BEV Technology® is the most advanced product in the industry ensuring the cleanest burning process without any smoke, smell or ash. The flame is produced by combusting ethanol vapours and has no direct contact with the liquid fuel.

GLASS SCREEN

The dedicated toughened glass panel covers and stabilizes the flame.

AUTOMATIC REFILLING SYSTEM

The automatic pump communicates with the device, delivering the necessary amount of fuel. There is no risk of overfilling the tank or spilling the fuel.

INTEGRATED CONTROL PANEL

The FLA3+ burner has an intuitive control panel with an LCD screen and inlet for automatic refuelling.

BEST BUILD QUALITY

The product passed extensive tests carried out by the leading certification institutes. It is manufactured according to UL standards and is O-TL certified, meeting the most demanding safety and quality requirements.

REMOTE CONTROL

Control the fire with the included remote, app on your smartphone or home automation system.



Fire Line Automatic 3+ (2490mm)

(BEV Technology®)

Fuel tank capacity	45.9 L
Maximum burn time	32 hours
Maximum heat output	22.5 kW
Minimum room cubature	225 m ³
Flame height regulation	6 stages
Weight	90.5 kg
Fuel type	bioethanol 86 - 96,6%
Flue	not required
Air change rate	1 space volume per hour
Power supply	230 V
Finish	black powder coating
Materials	steel, galvanized steel, toughened glass
Application	for indoor use only

CONTROL OPTIONS



included



included



optional

'PLANIKA N-CONTROL' APP

Control the fire with your smartphone!



O-TL certified 

Manufactured to UL standards

custom length
available on request



glass screens for See-Through and Room Divider housings are available separately

